



Owner's Manual

***Series 2000
Inverter / Power Backup Systems***

DoorKing, Inc.
120 Glasgow Avenue
Inglewood, California 90301
U.S.A.
Phone: 310-645-0023
Fax: 310-641-1586
www.doorking.com

Use this manual with the following models only.

Model 2000-080, 2000-081, 2000-082 manufactured July, 2009 and later with control circuit board 2352-010 and Xantrex Inverters

DoorKing, Inc. reserves the right to make changes in the products described in this manual without notice and without obligation of DoorKing, Inc. to notify any persons of any such revisions or changes. Additionally, DoorKing, Inc. makes no representations or warranties with respect to this manual. This manual is copyrighted, all rights reserved. No portion of this manual may be copied, reproduced, translated, or reduced to any electronic medium without prior written consent from DoorKing, Inc.

TABLE OF CONTENTS

Section 1 - Preface

Introduction	6
General Precautions	7
Personal Precautions	8
Batteries	9
Sizing the System	10

Section 2 – Inverter Operation

Inverter Control Panel.....	11
-----------------------------	----

Section 3 – Installation

Dimensions	13
3.1 Location	14
3.1.1 Typical Layout	15
3.1.2 Typical Layout	16
3.2 Mounting	
3.2.1 Conduits	17
3.2.2 Concrete Pad	17
3.2.3 Mounting the Unit	18

Section 4 – Wiring

Component Identification	19
4.1 AC Input Wiring	20
4.2 AC Output Wiring.....	21
4.3 Battery Wiring	22

Section 5 – Controls and Adjustments

Inverter Panel Identification	23
5.1 Control Board	
5.1.1 Normal Operation	23
5.1.2 Quick Open Operation	23
5.1.3 Terminal Description	23
5.1.4 Control Board Wiring	24
5.1.5 Operation Test	25

Section 6 – Maintenance

Monthly Maintenance.....	27
Trouble Shooting	27
Inverter Error Codes	28
Wiring Diagram	31
6.1 RMS Values, Meters and Measurement	32
6.2 Battery Cable Inductance	33
6.3 Ground vs. Lightning	34
Warranty	35
Life Support Policy.....	36

INTRODUCTION

What is the Model 2000 Inverter?

The DKS Series of Inverter / Power Backup systems are a unique style of battery backup devices. They are designed to provide an access control system with 120 volt AC power when the primary AC supply voltage source has failed. The Model 2000 will allow the access control system to maintain normal operation for an extended period of time.

Most vehicular gate operator battery backup systems are designed to provide a one time open function for the gate operator. These systems employ a controller, DC motor and batteries. They monitor the supply voltage and simply run the gate to the open position using the DC motor upon loss of AC power – a convenience device really. In addition, all access system components (telephone entry system, card readers, RF controls, loop detectors, entrapment prevention devices, etc.) do not function during this open cycle. These type battery backup systems are incapable of maintaining normal gate and access system operation during power outages.

The DKS Series 2000 is dramatically different than most gate operator battery backup systems. This is a true backup system designed to maintain power for all components of the access control system. During a loss of primary supply voltage, the Series 2000 converts DC battery power and provides 120 VAC operating power to multiple (up to six) gate operators and all other access system components such as the loop detectors, telephone entry system, card access system, RF controls, etc. This capability provides normal access control system operation during a power outage. All access system devices remain operational and all gate operator safety related and entrapment prevention devices continue to function normally.

How does the system work?

The DKS Model 2000 monitors the AC supply voltage and acts as a battery charger when AC power is present. This allows the system to maintain proper battery voltage without over-charging the batteries through its three-stage battery charging system. Upon a loss of AC power, the Model 2000 switches to inverter mode (32 milliseconds) converting the DC battery power to AC power to maintain operating voltage to the entire access control system. The Model 2000 will continue to provide AC operating power for an extended period of time. The length of time that the system can provide power is dependent on many factors including the number of devices connected to the system, access system usage, battery size, wire size, wire run distance, temperature, etc., but it is not unusual to receive 1-2 hours of continuous operation for a typical vehicular access control system. The model 2000 may also be programmed to open the gates immediately upon AC power loss.

While the system is in inverter mode, battery power is continuously monitored. When the Model 2000 determines that battery power is reaching critical levels, the system will sequentially open up to six gate operators in 30-second intervals, and will hold the gates open until primary power is restored. This prevents the vehicular access gates from blocking the roadway when battery power is depleted. Upon return of AC power, the model 2000 will initialize the gate operators to return the gate access system to normal operation.

Primary AC supply voltage is routed directly into the Model 2000. The system provides six 20-amp circuit breakers for high voltage power distribution and in fact acts as a power distribution sub-panel. There are three different models available to meet the access control system requirements:

- 1500 Watt, 12.5 amp maximum output
- 2400 Watt, 20 amp maximum output
- 2600 Watt, 30 amp maximum output

GENERAL PRECAUTIONS

This manual contains important safety and operating instructions and specifications for all models of the DKS Inverter / Backup Power Systems. This manual is the property of the owner of the equipment and must be left in their possession after the installation of the product is complete.

- Before installing, connecting any wiring, or using the backup power supply, read all instructions and cautionary markings on (1) the inverter/charger, (2) the batteries and (3) all appropriate sections of this instruction manual.
- **CAUTION** - Do not install or connect batteries to this unit until instructed to do so. Failure to comply with this instruction can cause damage or complete failure of the inverter unit.
- **CAUTION** - To reduce risk of injury, use only deep-cycle lead acid batteries.
- Do not expose the inverter/charger to rain, snow or liquids of any type. Do not disassemble the inverter/charger; take it to a qualified service center when service or repair is required. Incorrect re-assembly may result in a risk of electric shock or fire.
- To reduce risk of electric shock, disconnect all wiring from the inverter/charger before attempting any maintenance or cleaning. Turning off the inverter will not reduce this risk.
- **WARNING - WORKING IN VICINITY OF A LEAD ACID BATTERY IS DANGEROUS. BATTERIES GENERATE EXPLOSIVE GASES DURING NORMAL OPERATION.**
- Never charge a frozen battery.
- Be extra cautious when working with metal tools on, or around batteries. The potential exist to drop a tool and short-circuit the batteries or other electrical parts resulting in sparks that could cause an explosion.
- This backup power system is to be used with batteries that supply a nominal voltage of 24 VDC. This is provided by connecting two, 12-volt batteries in series.
- **GROUNDING INSTRUCTIONS** - This backup power supply must be connected to a grounded, permanent wiring system. All installations should comply with all national and local codes and ordinances.

PERSONAL PRECAUTIONS

- Someone should be within range of your voice to come to your aid when you work near batteries.
- Have plenty of fresh water and soap nearby in case battery acid contacts skin, clothing, or eyes.
- Wear complete eye protection and clothing protection. Avoid touching eyes while working near batteries. Wash hands when done.
- If battery acid contacts skin or clothing, wash immediately with soap and water. If acid enters eyes, immediately flood eyes with running cool water for at least 15 minutes and get medical attention immediately.
- Baking soda neutralizes lead acid battery electrolyte. Keep a supply on hand in the area near the batteries.
- NEVER smoke or allow a spark or flame in vicinity of the batteries.
- Be extra cautious when working with metal tools on and around batteries. The potential exists to short-circuit the batteries or other electrical parts that may result in a spark that could cause an explosion.
- Remove personal metal items such as rings, bracelets, necklaces, and watches when working with electrical circuits. These items can cause a short-circuit current high enough to weld a ring, or the like, to metal causing severe burns.
- If a remote or automatic start system is used, disable the automatic starting circuit and/or disconnect the system from the backup power supply while servicing to prevent accidental starting during servicing.

BATTERIES

Batteries come in different sizes, types, amp hours, voltages and chemistries. Standard automobile batteries, called starting batteries, are designed to provide high starting current for short periods of time. These batteries will quickly drain under continuous loads and their life span is greatly reduced when the battery is discharged on a repetitive cycle.

Deep cycle batteries are designed to handle continuous or repetitive loads for an extended period of time. They will operate with repeating cycles (discharge/charge) and can provide sufficient power when discharge is as low as 80%. **This makes these type batteries best suited for use with the Model 2000 inverter.** These batteries are rated in AMP HOURS, which indicates how long the battery can supply power under a continuous load. For example, 1 amp hour means the battery can supply 1 amp for 1 hour, or 4 amps for 15 minutes. A 100-amp hour battery can supply 1 amp for 100 hours.

Batteries come in all different sizes. Many have "group" sizes, which is based upon the *physical size* and terminal placement. It is NOT a measure of battery capacity. The battery compartment in the model 2000 can accommodate two (2) Group 24 sized batteries. These are 12-volt batteries rated up to 80 amp-hours, are economical and readily available. The Model 2000 requires two batteries connected in series to supply 24 volt DC power to the inverter.

BATTERIES MUST HAVE SCREW TYPE TERMINALS. DO NOT USE BATTERIES WITH CLAMP TYPE TERMINALS.

Batteries are the backup power system's fuel tank. The larger the batteries, the longer the system can operate before recharging is necessary. An undersized battery bank results in reduced battery life and disappointing system performance.

Battery Terminology

- Electrolyte - Typically a mixture of water and sulfuric acid, it is commonly referred to as battery acid.
- Plates - Originally made of lead, they are now made of lead oxide. Plates are the part of the battery that collect current and are connected to the battery terminals. There are several plates in each cell, each insulated from the others by separators.
- Sulfating - As a battery discharges, its plates are progressively covered with lead sulfate. During recharging, the lead sulfate is removed from the plates and recombined with the electrolyte. If the lead sulfate remains on the plates for an extended period of time (over two months), it hardens, and recharging will not remove it. This reduces effective plate area and the battery capacity is diminished.
- Stratification - Over time the batteries' electrolyte (liquid) tends to separate. The electrolyte at the top of the battery becomes watery while at the bottom it becomes more acidic. This effect is corrosive to the plates and reduces battery life.
- Deep Cycle - A deep cycle occurs when a battery has been discharged such that less than 20% of its capacity remains (80% discharge).
- Temperature Compensation - The optimum full charge voltage is temperature dependent. As temperature decreases the proper voltage for each charge stage needs to be increased. The temperature probe in the Model 2000 automatically re-scales charge voltage settings for ambient temperature. The compensation slope based on cell voltage is -2.17mv per degree F. per cell. This also decreases the charge voltage when the battery is hot to reduce gassing.

SIZING THE SYSTEM

The loads on the backup power system are seldom constant. Typically, large loads are operated for only short periods of time, such as when a gate operator motor first starts. The Model 2000 has circuitry that allows the system to operate at power levels that exceed the continuous power rating of the inverter for these short periods.

In order to select the proper model of the backup power system to use, you need to know the amount of power that the vehicular gate operator(s) draws during its run cycle. If more than one operator is connected to the backup power system, add the power of all the gate operators in the system together. The table shows the maximum run power required for DoorKing vehicular gate operators. If other operator brands are to be connected to the system, power consumption is determined by the formula **WATTS=VOLTS X AMPS**. Use the ratings on the nameplate of the motor.

MODEL	MAX RUN AMPS	RUN WATTS
610, 615, 620, 630 (1/2 hp) 907, 910, 915 (1/2 hp) 6100, 6300, 6500 (1/2 hp) 9000, 9070, 9100, 9150, 9310 (1/2 hp)	5.4 @ 115 V	621
605,905, 6050, 9050	4.3 @ 115 V	495
1601, 1603, 1100, 1150	5.4 @ 115 V	621
625, 630, 915 (1 hp) 6300, 6500, 9000, 9150, 9310 (1 hp)	9.7 @ 115 V	1115
1602	9.7 @ 115 V	1115
920, 9200, 9210, 9220	14 @ 115 V	1610

Even though their power consumption is minimal, accessory items and other access control system components should also be considered when calculating the Model 2000 power requirements. For example, a DoorKing model 1815 telephone entry system draws 250 ma at 16 volts, which equals a power consumption of 4 watts (.25 x 16).

Once you determine the watts that will be required to run the vehicular access control system, select the backup power system model that exceeds the amount of power required for the system. For example, if two 6100 operators are connected to the system, they will draw 1242 watts of power (621 + 621). The model 2000-080 (1500 Watt) would be suitable for this application.

MODEL	MAX POWER	MAX AMPS
2000-080, 1500 Watt	1500	12.5
2000-081, 2400 Watt	2400	20.0
2000-082, 3600 Watt	3600	30.0

If four 6100 operators are connected to the system, the model 2000-082 (3600 Watt) would be required because the total power consumption is 2484 watts (621 x 4) and the four operators will draw up to 21.6 amps (5.4 x 4). The table shows the maximum continuous (1 hour) output power and current that the system is capable of delivering when in inverter mode. These factors must be considered when determining which model of power backup system to use.

SECTION 2 – INVERTER OPERATION

Shown below are the controls and indicator lights on the front panel of the inverter/charger. These control and provide information when the system is in either inverter or battery charging mode of operation.

NOTE: ALL SETTINGS ON THE INVERTER CONTROL PANEL HAVE BEEN PRESET AT THE FACTORY. DO NOT CHANGE THEM. Refer to the Xantrex Trace Series manuals included with this system for information on the inverter control panel functions and settings.

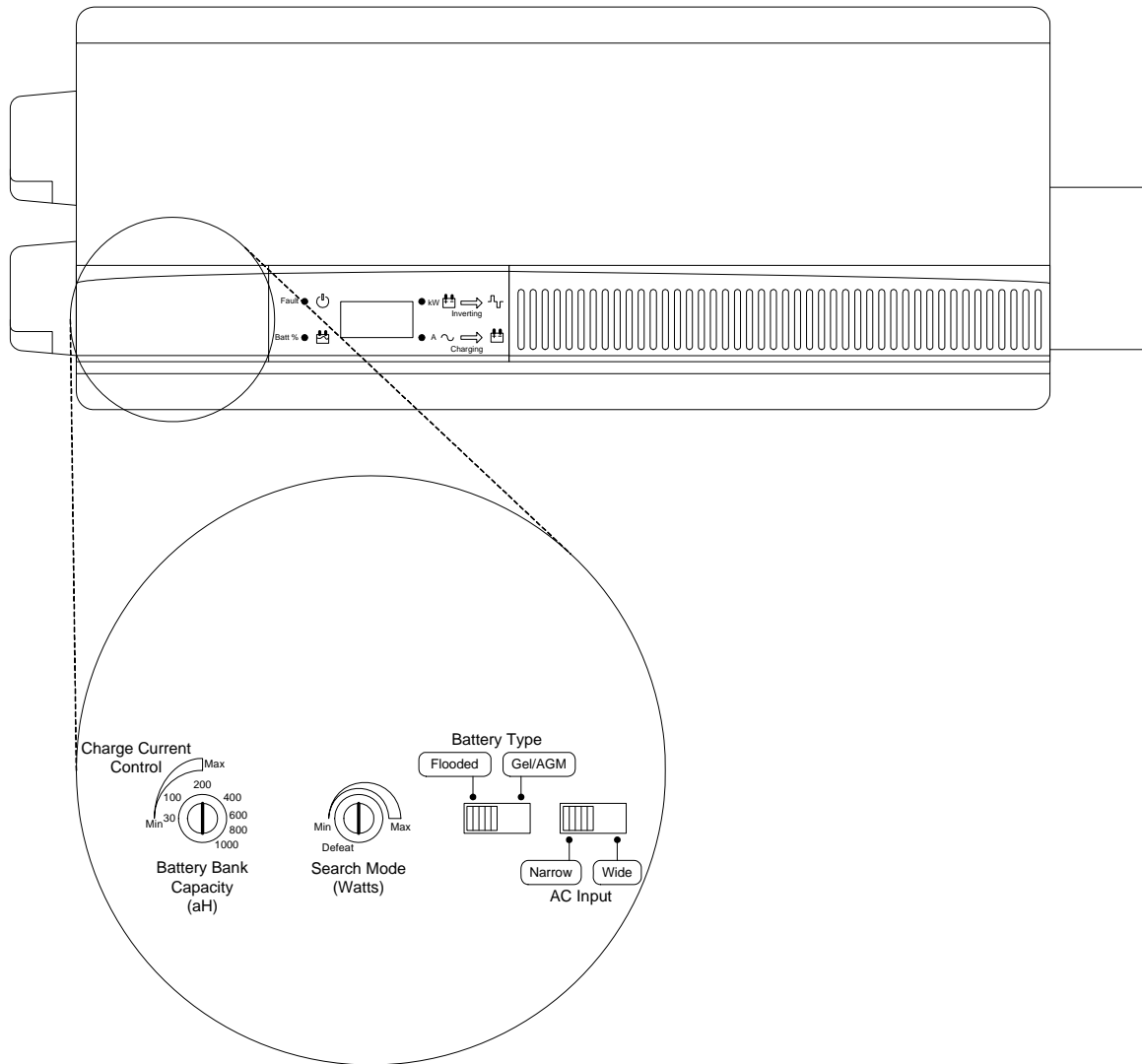

SECTION 3 – INSTALLATION

WARNING!!

DO NOT CONNECT BATTERIES TO THE BACKUP POWER SYSTEM UNTIL INSTALLATION AND WIRING OF THE SYSTEM IS COMPLETE. THE BATTERIES WILL BE THE LAST COMPONENT TO BE CONNECTED PRIOR TO POWERING THE SYSTEM FOR THE FIRST TIME.

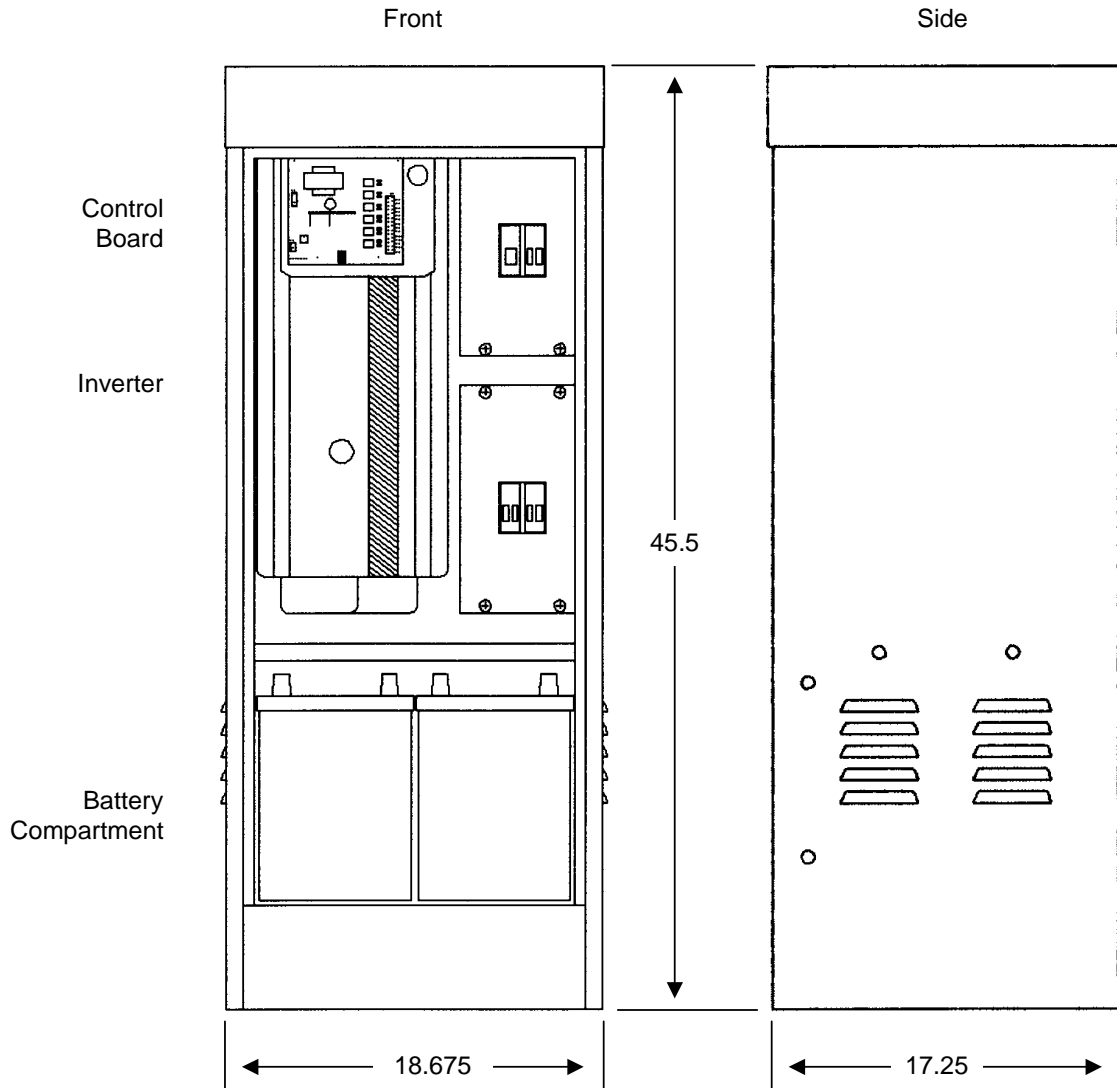

3.1 LOCATION

Prior to installing the backup power system, careful thought must be given as to where the unit will be installed. The system operates best when it can be installed as physically close as possible to the equipment that it is intended to operate during power outages. This reduces line loss. The backup power system also acts as a power distribution panel. Main AC power enters the backup power system and is distributed through the unit to up to six branch circuits to power the access control system. Each branch circuit is protected with a 20-amp circuit breaker.

When planning your system and laying out conduit runs, primary AC input power is run directly from the main electrical panel to the backup power system. From the backup power system, separate conduit runs will be made to each vehicular gate operator that the system is backing up. Because of this, the primary AC power wires may be quite large depending on the number of gate operators being backed up and the wire run distance. Branch conduits (from the backup power system to the individual operators) should be a minimum $\frac{3}{4}$ -inch. Conduits may need to be larger depending on the size and number of wires being run, and on local electrical codes.

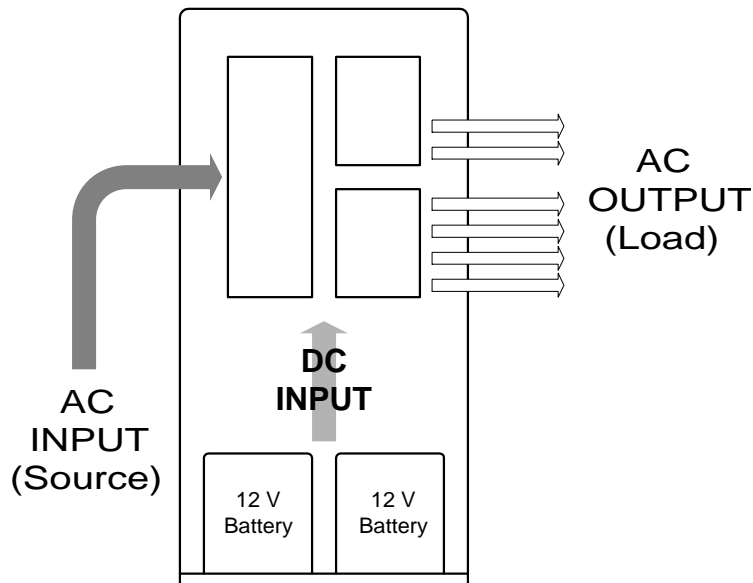

The layouts on the next pages show possible methods of routing conduits in a typical two-lane gate system that uses both barrier gate operators and a slide or swing gate operator on each traffic lane. The access control system may be powered from a transformer box (which is powered from the Model 2000) or from convenience outlets in the gate operators. Plug-in loop detectors are powered directly from the gate operators.

The effective capacity of a battery is reduced when cold. This phenomenon is more significant with lead-acid type batteries than with other batteries. When the internal temperature of a lead-acid battery is 32°F (0°C), the capacity can be reduced by as much as 50%. This effectively reduces the size of the systems "gas tank." This should be considered when designing the access system. If extremely cold temperatures are expected, you should consider installing the backup system in a heated equipment room.

The Model 2000 should be protected from high temperatures as well. High battery temperatures will result in short battery life. Install the backup system in a shaded area or inside an air-conditioned equipment room if extremely high temperatures are the norm.

3.1.1

In this layout, the Model 2000 is installed close to the vehicular gate system. Note that incoming AC power is routed into the Model 2000, and is then distributed to the various devices to be powered. **With this type of layout, it is critical that the AC wires that provide power to the Model 2000 must be of a sufficient size to handle the power required by ALL the operators powered from the Model 2000.** This may require a fairly large wire size, such as 8, 6 or 4 AWG depending on the number of operators and wire run distances involved. It is best to have a licensed electrician determine the proper wire size required.

Incoming AC power is distributed through the Model 2000 to each of the gate operators. Access control devices are powered from accessory transformers plugged into the transformer box (DoorKing Model 1200), which is also powered from the Model 2000. Refer to the gate operator installation instructions or consult a licensed electrician to determine the proper wire size required to supply adequate power to the gate operators.

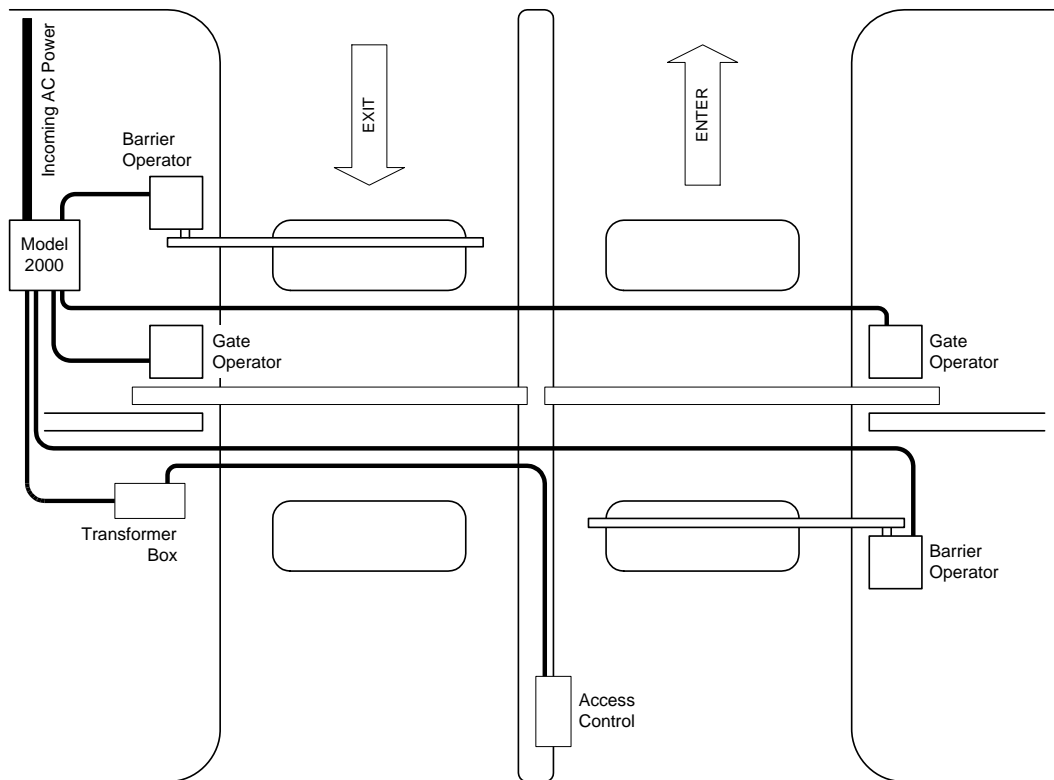

3.1.2

In this layout, the Model 2000 has been positioned close to the AC power distribution panel rather than being installed at the gate site. AC power is routed into the Model 2000 from the distribution panel and is then distributed to the various devices to be powered. **It is critical that the AC wires that provide power to the Model 2000 be of a sufficient size to handle the power required by ALL the operators powered from the Model 2000.** This may require a fairly large wire size, such as 8, 6 or 4 AWG depending on the number of operators and wire run distances involved. It is best to have a licensed electrician determine the proper wire size required.

Power is distributed from the Model 2000 to each of the gate operators. Refer to the gate operator installation instructions or consult a licensed electrician to determine the proper wire size required to supply adequate power to the gate operators.

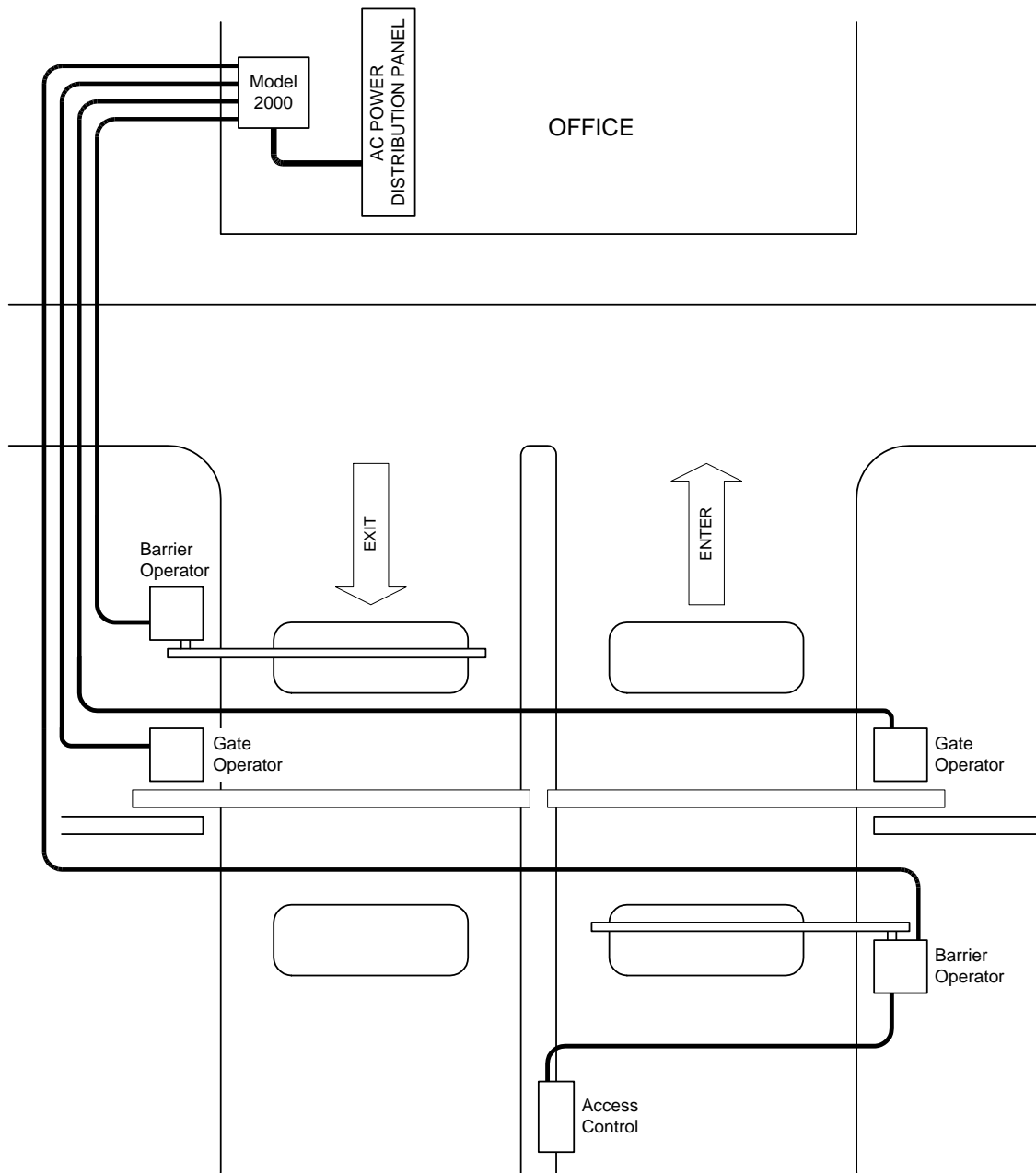

3.2 MOUNTING

3.2.1 Conduits

All wiring into and out of the backup power system enters the unit through the concrete mounting pad and is routed up behind the battery compartment into the circuit breaker panels. Conduits should be located so that they are in a straight line running along the back of the unit. However, there is 3.5 inches of clearance from the bottom of the battery shelf to the top of the mounting pad. Conduits can be stubbed up into this space, and then the wires can be routed as needed. The space between the back of the battery compartment and the back of the backup power system is 1.5 inches.

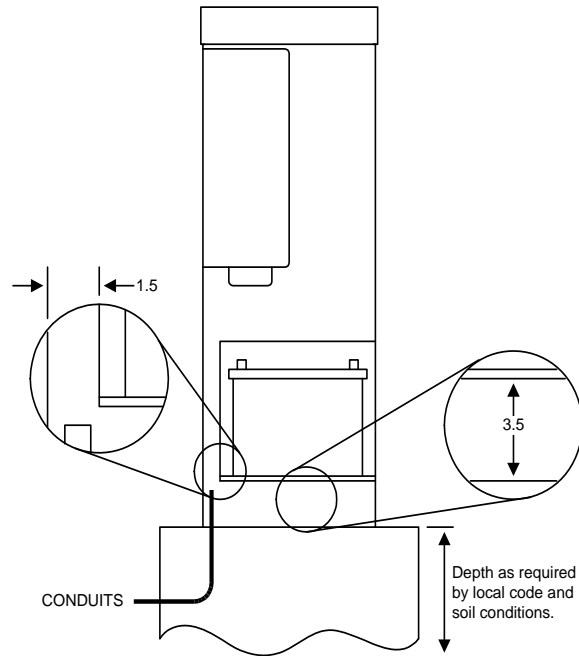

3.2.2 Concrete Pad

The backup power system must be mounted on a concrete pad. Be sure to check with local building codes to determine the depth of the pad. Be sure that all conduits are in place.

1. Construct a form for the mounting pad according to the figures shown below. Be sure to level the top edge of the form. The depth of the pad is determined by soil conditions and local building codes. The top surface of the pad must be a minimum of four (4) inches above ground level. **The size of the pad allows 4 inches of clearance around the Model 2000.**
2. Set conduits and reinforcing bars and/or wire mesh.
3. Mix the concrete according to the manufacturers instructions. Pour the mixture into the form and tamp. Level and finish the surface after pouring is complete. Do not set anchor bolts in the concrete. Sleeve anchors are used to secure the backup power system to the pad.
4. Allow the pad to cure for 48 hours before removing the forms or mounting the backup power system.

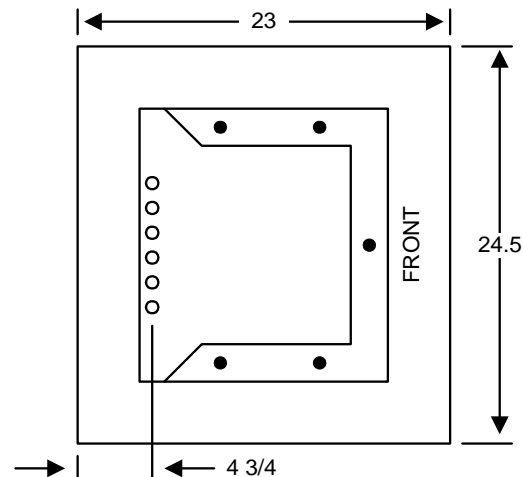

3.2.3 MOUNTING THE UNIT

These steps require two people to perform them. The Backup Power Unit is heavy and will require lifting. Attempting to lift this unit by yourself can result in serious injury. A hammer drill will be required in these steps to drill the mounting holes in the concrete pad for the sleeve anchors. Mounting of the Backup Power Unit to the concrete pad requires five (5) 3/8 x 3 sleeve anchors, which are not supplied with the unit.

1. Remove the shipping carton from the Backup Power Unit. Unlock the cabinet door (the keys are taped to the back of the unit) and set it aside.
2. Remove the wood shelve from the bottom of the unit. Do not discard this shelf; it will be replaced after mounting is complete.
3. Remove the four bolts that secure the Backup Power Unit to the shipping pallet, and then lift the unit off of the pallet. **CAUTION: The Backup Power Unit is heavy! Do not attempt to lift it off the shipping pallet, or place it on the mounting pad yourself. Placement of this unit requires two people.**
4. Place the Backup Power Unit onto the concrete pad being careful not to damage conduits or wiring already installed. **Do not drop the Backup Power Unit.** Position the unit on the pad so that the conduits are located inside the cabinet. If the pad was formed to the dimensions shown in section 3.2.2, there will be four (4) inches of clearance around the cabinet to the edge of the concrete pad.
5. Position the Backup Power Unit on the pad in the location desired. Mark the location of the five (5) mounting holes on the concrete pad. All mounting holes are on the inside of the cabinet. There are two mounting holes on each side of the cabinet, and one in the front of the cabinet.
6. After the holes are marked, remove the unit from the pad. Use a hammer drill to drill the mounting holes. Drill the hole to the required depth and diameter for the sleeve anchor being used. After drilling all the holes, be sure to clean out the holes to remove the concrete dust.
7. Position the Backup Power Unit onto the concrete pad being sure that the mounting holes in the cabinet are positioned over the holes that were drilled in the mounting pad. Route any wiring that may be in place up the back of the cabinet and into the top electrical compartment.
8. Place the sleeve anchors through the cabinet and into the concrete. Tap the sleeve anchors into the holes so that they are firmly seated. Be sure that the nuts and washers are in place on the sleeve anchor before tapping into the mounting holes.
9. Tighten the bolts two or three turns from the finger tight position to achieve the proper anchor setting.
10. Clean out any debris from the bottom of the Backup Power Unit. Re-install the wood shelving removed in step 2.

SECTION 4 – WIRING

WIRING OF THE MODEL 2000 INVERTER / POWER BACKUP SYSTEM SHOULD BE PERFORMED BY A QUALIFIED, LICENSED ELECTRICIAN. CONSULT LOCAL CODE FOR PROPER WIRE SIZE, CONNECTORS AND CONDUIT REQUIREMENTS.

The Model 2000 is protected with a 30 Amp circuit breaker on the AC input power line. Each of the six branch circuits is protected with a 20 Amp circuit breaker.

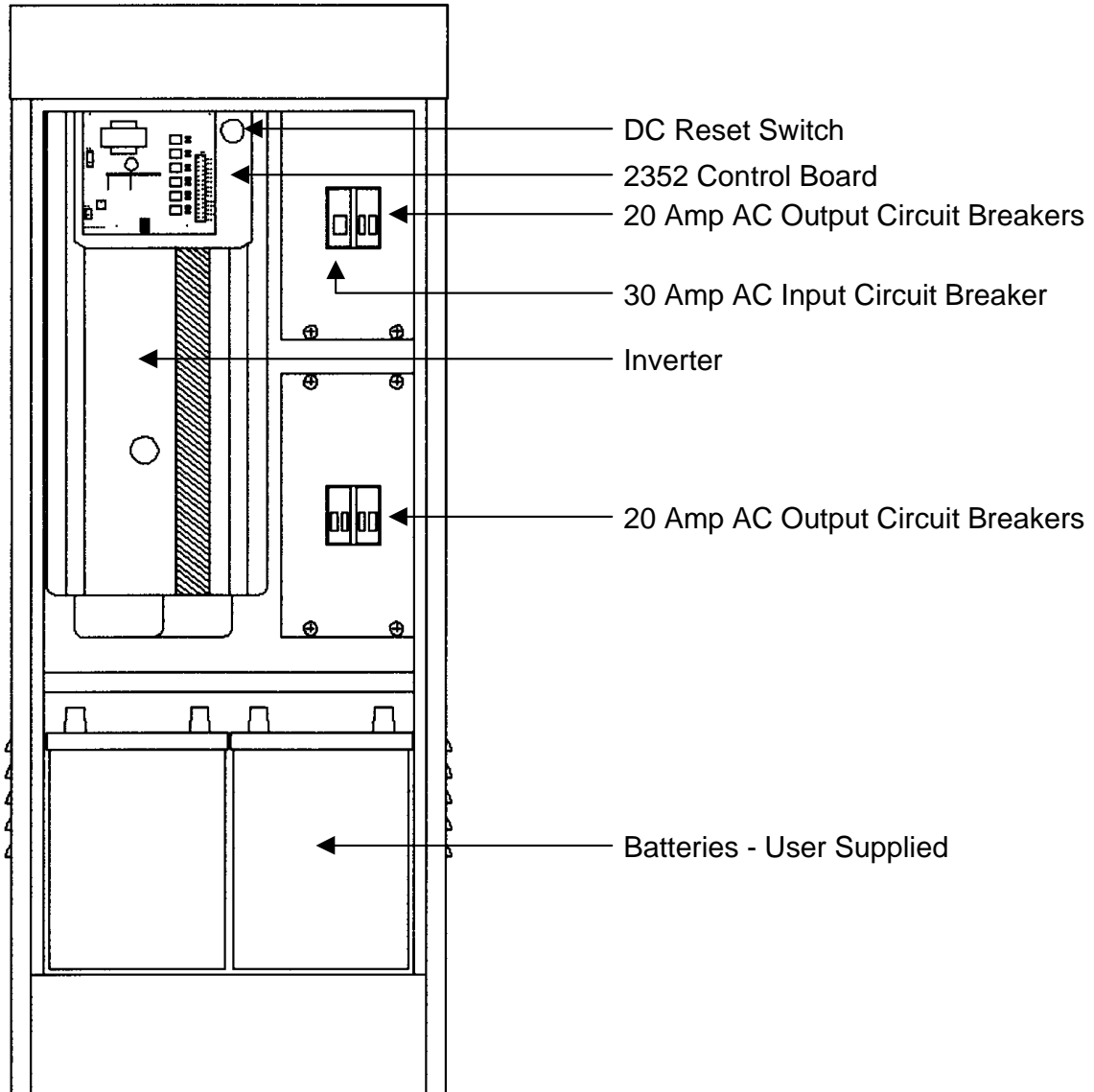

4.1 AC INPUT WIRING

Be sure that the AC source power is disconnected or shut-off before attempting to connect the AC input wiring to the Backup Power System. Since the Backup Power System acts as a distribution panel, the AC input wiring must be sized large enough to power the load(s) connected to the Backup Power System. Under no circumstances should the AC input wiring be sized less than 10 AWG.

Minimum Wire Size	
Model	AC Input
2000-080	10 AWG
2000-081	6 AWG
2000-082	6 AWG

Be sure that the batteries ARE NOT CONNECTED at this time.

1. Remove the circuit breaker panel cover from the top breaker panel box.
2. Confirm that the AC source power is disconnected or that the circuit breaker protecting this line is in the OFF position.
3. Feed the wires through the appropriate openings. Use fittings or strain relief's (consult local and national codes).
4. Connect the ground (GREEN) wire to the ground buss bar.
5. Connect the neutral (WHITE) wire to the neutral buss bar. Torque neutral and ground buss bar to (small terminals) 20 lb-in for 14-10 AWG, 25 lb-in for 8 AWG, and 35 lb-in for 6 AWG. Torque large terminals to 35 lb-in for 14-10 AWG, 40 lb-in for 8 AWG, and 45 lb-in for 6 AWG and larger.
6. Connect the hot (BLACK) wire to the AC input circuit breaker. Torque main terminal to 35 lb-in for 14-10 AWG, 40 lb-in for 8 AWG, and 45 lb-in for 6 AWG and larger.
7. Place the 30 AMP AC input circuit breaker to the OFF position.
8. **DO NOT APPLY POWER AT THIS TIME.**

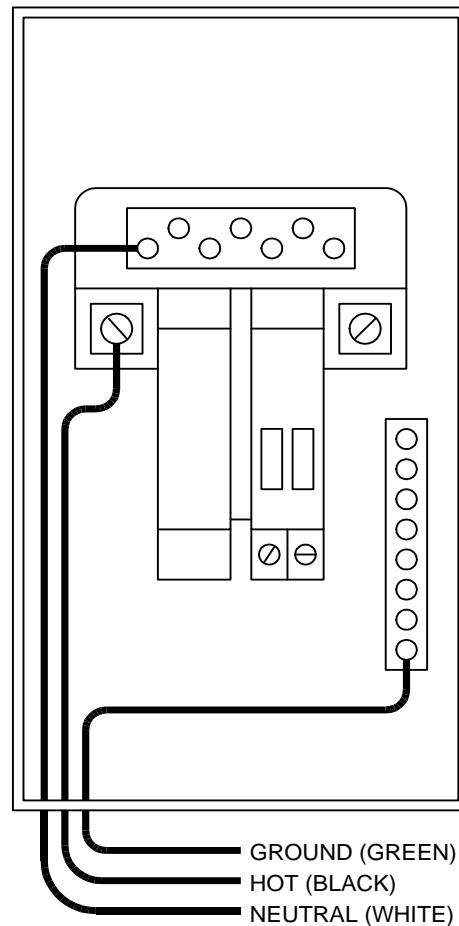

4.2 AC OUTPUT WIRING

The Backup Power System provides six (6) output circuits, each of which is protected by a 20-amp circuit breaker. When using this system to provide backup power for vehicular gate operators, each gate operator should be connected to its own circuit breaker. In this manner, the system will provide power for up to six (6) gate operators. The access control system (telephone entry, card readers, etc.) and other peripheral devices (loop detectors) are normally powered from the gate operator. However, it is possible to power these devices (a telephone entry system, for example) from one of the six circuit breakers if extra circuits are available in your application. The Model 1200 Transformer Box is ideal for this application and can hold up to four (4) 20 VA accessory transformers.

IMPORTANT! The output of the Backup Power System should at no time be connected to public power or a generator. This condition is far worse than a short circuit and can destroy the inverter unit. IF the unit survives this condition, it will shut down until corrections are made. Review the installation diagrams before making any connections.

1. Remove the circuit breaker panel covers.
2. Feed wiring through the appropriate openings. Consult local codes for proper wire size (See minimum recommended wire size chart on previous page). Use fittings or strain relief's (consult local and national codes).
3. Connect HOT load wires to circuit breakers as shown. We suggest that you color-code the different load wires.
4. Connect NEUTRAL (WHITE) load wires to neutral bar as shown.
5. All load equipment must be grounded (GREEN WIRE).
6. Torque main terminal to 35 lb-in for 14-10 AWG, 40 lb-in for 8 AWG, and 45 lb-in for 6 AWG and larger. Torque neutral bar (small terminals) to 20 lb-in for 14-10 AWG, 25 lb-in for 8 AWG, and 35 lb-in for 6 AWG. Torque large terminals to 35 lb-in for 14-10 AWG, 40 lb-in for 8 AWG, and 45 lb-in for 6 AWG and larger.
7. Replace circuit breaker panel covers.
8. Place all circuit breakers in the OFF position.

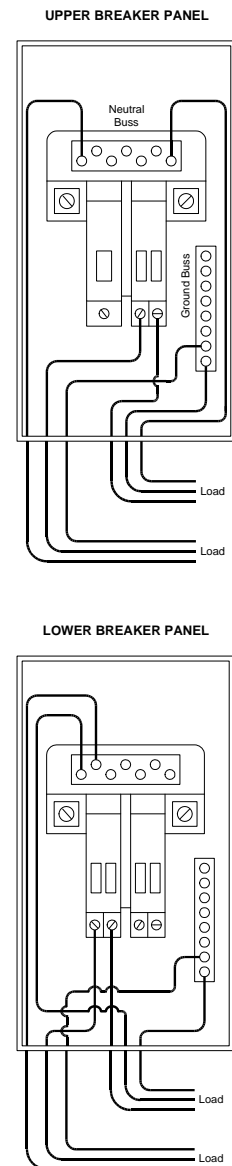

4.3 BATTERY WIRING

WARNING!! THE INVERTER IN THIS BACKUP POWER SYSTEM IS NOT REVERSE-POLARITY PROTECTED!!

If the positive terminal of the battery is connected to the negative terminal of the inverter and vice versa, the probable result is failure of every power FET in the inverter. To compound your misfortune, this type of failure is very obvious AND IS NOT COVERED UNDER THE WARRANTY. Pay close attention and double check when making the battery connections.

The Backup Power System's maximum peak current requirements are very high. If battery cables are too small and/or connections are loose, efficiency and maximum output power are degraded. Small cables or loose connections can cause dangerous overheating of the wire and/or terminals.

After the batteries are connected, tape the cables together every few inches with electrical tape. This reduces the inductance of the wire resulting in a better waveform and less current in the inverter's filter capacitors. This directly relates to efficiency. Refer to page 8 of this manual for information on the type of batteries that should be used with the Backup Power System.

NOTE: CONNECTING THE BATTERY CABLES WILL CAUSE AN ARC USUALLY ACCOMPANIED BY A "SNAP". THIS IS NORMAL - DON'T LET IT SCARE YOU.

WARNING!! Never disconnect the batteries while the system is delivering power or the battery charger is operating. Always turn the system OFF first.

1. Check to be sure that all circuit breakers in the Backup Power System are in the OFF position.
2. Locate the RED and BLACK battery cables in the battery compartment of the Backup Power System. **DO NOT DISCONNECT these cables from the inverter. The red and black cables have been connected at the factory and have been properly torque to 10-12 ft lbs.**
3. Place the batteries near the battery compartment so that connections to them can be made. Locate the black jumper cable that was included with the unit. Connect one end of this cable to the NEGATIVE terminal of one battery, and connect the other end to the POSITIVE terminal of the other battery. This connects the two 12 volt batteries in series to provide 24-volt DC power to the inverter.
4. **OBSERVE BATTERY POLARITY!! Connect the RED battery cable to the POSITIVE (+) terminal. Connect the BLACK battery cable to the NEGATIVE (-) terminal. When you connect the last cable to the battery, this will cause an arc usually accompanied by a "snap." This is normal.**
5. Place the batteries in the battery compartment being careful not to short the battery terminals to the top of the battery compartment.
6. A temperature sensor is mounted on the top of the battery compartment. Be careful of this sensor when placing the batteries in the battery compartment.

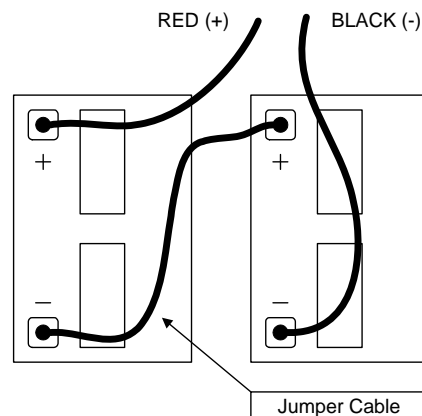

SECTION 5 – CONTROLS AND ADJUSTMENTS

The Backup Power System uses a battery control board that monitors the charge condition of the battery bank. This control board will command each of the gate operators connected to the system to open sequentially thirty (30) seconds apart when the batteries reach a critical level and can no longer maintain system operation. This assures that the vehicular gates will not remain in a closed position if the battery power is depleted.

5.1 CONTROL BOARD

5.1.1 NORMAL OPERATION

The 2352 circuit board monitors AC power during normal operation and DC battery voltage during inverter operation. When AC power fails, the system automatically switches from charger mode to inverter mode. As the inverter draws DC power to operate the access control system, the 2352 monitors the DC battery voltage. When the battery voltage reaches a critical level and access system operation can no longer be maintained, the 2352 board will begin to command each of the gate operators powered by the system to open sequentially in 30-second intervals, and will hold the gate operators in the open position.

5.1.2 QUICK OPEN OPERATION

The 2352 board can be set to immediately open the gate operators upon AC power loss if this type of operation is desired. Simply set programming switch 1 to the ON position. (Note: Programming switches 2-3-4 are not used and should be left in the OFF position). If programming switches on the 2352 board are changed, you must turn off AC power AND press the DC reset switch for 5 seconds for the 2352 board to recognize the new switch settings.

When AC power is restored, the 2352 control board will release each of the hold open relays one at a time, and will then re-activate each relay for one (1) second. This resets the gate operator control board so that the operators will return to normal operation.

5.1.3 TERMINAL DESCRIPTION

P1: 1	24 VDC Input – Positive
P1: 2	24 VDC Input – Negative
P2:	Ground
P3: 1	120 VAC Input
P3: 2	120 VAC Input
P4: 1-2	Operator 1 Control Relay
P4: 3-4	Operator 2 Control Relay
P4: 4-6	Operator 3 Control Relay
P4: 7-8	Operator 4 Control Relay
P4: 9-10	Operator 5 Control Relay
P4: 11-12	Operator 6 Control Relay
P4: 13-14	Not Used

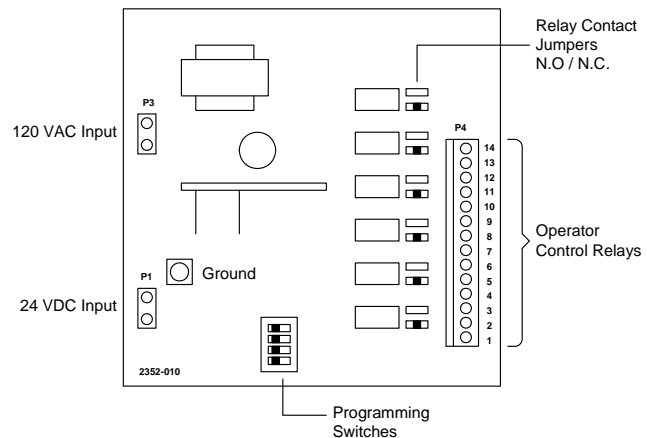

5.1.4 CONTROL BOARD WIRING

Terminals P1, P2 and P3 are factory wired.

The relay contacts on terminals P4, 1-14 are factory set for Normally Open (N.O.) operation. If Normally Closed (N.C.) relay contacts are required, move the contact jumper for the desired relay from the N.O. pins to the N.C. pins.

Connect the respective control relay contacts to the open input on the gate operators to be backed up by this system. Use 18 AWG (minimum) wire for control relay connections.

The block diagram shows how the Model 2000 can supply backup power to each of the gate operators and supplies power to an access control system to maintain complete and normal operation during power outages.

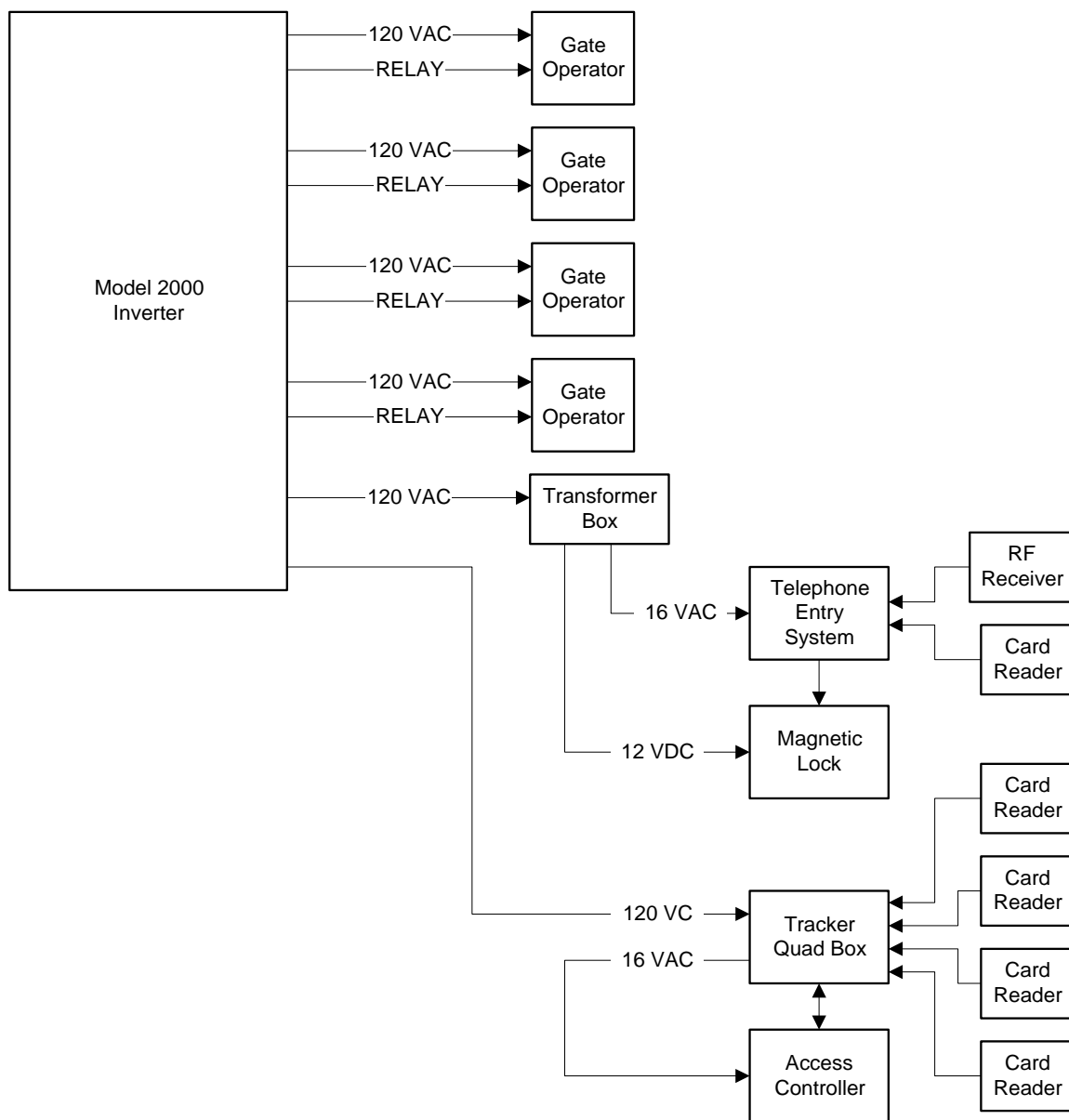

5.1.5 OPERATION TEST

BEFORE TESTING THE BACKUP POWER SYSTEM, BE SURE THAT ALL WIRING IS COMPLETE AND THAT THE BATTERIES ARE PROPERLY CONNECTED AND FULLY CHARGED.

1. Place the main AC input circuit breaker to the ON position. Place each of the branch circuit breakers that are being used to the ON position.
2. Operate the access system to assure that all components of the system function normally from the AC power source.
3. NORMAL OPERATION – Switch 1 on the 2352 circuit board is OFF¹. Place the main 30-amp AC input circuit breaker to the OFF position to simulate a power interruption. The inverter LED should be in the inverter mode and the access system should remain in normal operation with no disruption in service. Operate the access system to assure that all components are operating normally. This includes the vehicular gate operator(s), loop detectors, telephone entry system, card readers, keypads, RF access control, emergency vehicle entry devices, etc.
4. QUICK OPEN OPERATION – Switch 1 on the 2352 circuit board is ON¹. Place the main 30-amp AC input circuit breaker to the OFF position to simulate a power interruption. Each of the gate operators connected to the Backup Power System will sequentially open in 30-second intervals and should remain open.
5. Place the main AC input circuit breaker to the ON position. After approximately 40 seconds, the system will return to operating from the main AC power source. (If quick open operation was selected, each gate operator will be given a reset command so that it can resume normal operation).

Note¹: Remember you must turn off AC power and press the DC reset button located on the front panel for at least 5 seconds for the 2352 circuit board to recognize and switch setting changes.

SECTION 6 – MAINTENANCE

MONTHLY MAINTENANCE

At the minimum, check the level of the electrolyte in each battery cell once a month after the batteries have been charged, not before. It should be about ½-inch above the top of the plates, but not completely full. Most batteries have a plastic cup, which the electrolyte should just touch when full. Don't overfill the batteries or the electrolyte will spill out of the batteries during charging. **Only refill the batteries with distilled water** – spring water and regular tap water may have high mineral levels which can poison the battery chemistry and reduce battery life.

Check the battery interconnections for tightness and corrosion. If any corrosion is found, disconnect the cables and carefully clean with a mild solution of baking soda and water. **DO NOT ALLOW THE SOLUTION TO ENTER THE BATTERY.** Rinse the top of the battery with clean water when finished.

To reduce the amount of corrosion on the battery terminals, coat them with a thin layer of petroleum jelly or anti-corrosion grease available from automotive parts stores or battery suppliers. **Do not apply any material between the terminal and the cable lugs** – the connection should be metal to metal. Apply the protective material after the screws have been tightened.

TROUBLE SHOOTING GUIDE

The table below shows the possible error codes on the display screen and the description of the fault or warning.

When the Inverter is in **Warning** status, the Fault LED is flashing red, the audible alarm is beeping at one second intervals and the display is alternately showing the error code and the power or current (depending on Invert or Charge mode of the inverter).

When the Inverter is in **Fault** status, the Fault LED is solid red, the audible alarm is beeping continuously and the display is continuously showing error code.

If the reason for the error is corrected while the Inverter is still in Warning status, not Fault status, then the unit will automatically clear the warning and restart. If the error has progressed to Fault status the Inverter will shut down and will have to be manually restarted.

To Clear a Fault and Restart the Inverter:

1. **Press the ON/STANDBY switch once to clear the error.**
2. **Press the ON/STANDBY switch again to manually turn the inverter on.**

INVERTER ERROR CODES

Error Code	Fault or Warning	Description	Solution
F 01	Fault	Fan is locked or disconnected.	This is a mechanical blockage of the fan. Ensure the inverter is fully off. Carefully inspect for foreign objects lodged in the fan and remove as necessary. Manually restart the inverter. If condition persists, contact DKS Tech Support.
F 02	Warning	The inverter is over heating, but still functioning. If the over heating is not corrected in 40 seconds, the warning will become a fault.	Allow the inverter to cool. Improve ventilation around the unit or install in a cooler location.
F 02	Fault	The F 02 Warning has become a fault. The inverter has stopped inverting or charging and is waiting to cool down before automatically restarting.	Allow the inverter to cool. Improve ventilation around the unit or install in a cooler location.
F 03	Warning	The inverter has not detected a battery temperature sensor during the startup test. After 5 seconds, the warning will automatically clear. The battery temperature sensor connected to the inverter has an error. Normal inverting and charging is not affected by this warning. The inverter will continue the charge cycle using the last known temperature reading, then will continue at the default temperature of 77°F (25°C).	Either connect a battery temperature sensor, or be aware of the impact of not using one. Press the ON/STANDBY switch once to clear fault. Check the battery temperature sensor connections and replace the battery temperature sensor if necessary.
F 03	Fault	The battery temperature sensor has detected a temperature outside of the safe operating temperature of -4°F to 140°F (-20°C to 60°C).	The inverter has shut down for safety reasons. Check the batteries and adjust location / ventilation of the batteries. Manually restart the inverter.
F 04	Fault	Inverter AC transfer relay has failed.	The inverter has shut down for safety reasons. Manually restart the inverter. If condition persists, contact DKS Tech Support.
F 05	Warning	The electrical devices connected to the AC output have exceeded the power rating of the inverter (either too many devices, or devices with too high power consumption). The inverter is still functioning, but if the over-load does not self-correct in 10 seconds, the warning will become a fault.	No action required. The warning is in place to prevent shutdown in the event of a quick, self corrected power surge.
F 05	Fault	The F 05 warning has become a fault. The electrical devices connected to the AC output have exceeded the power rating of the inverter (either too many devices, or devices with too high power consumption).	Check the power rating of the connected devices. Remove devices until the combined power consumption is less than the power level of the inverter (1500, 2400 or 3600 watt). Manually restart the inverter.
F 06	Warning	The inverter has been short circuited at the AC output. The unit is still functioning, but if the short circuit does not self-correct in 10 seconds, the warning will become a fault.	No action required. The warning is in place to prevent shutdown in the event of a quick, self corrected short at the inverter output.
F 06	Fault	The F 06 warning has become a fault.	Check the connected loads for short circuits. This condition is also present in case of extreme overloading (i.e., when the load requires more than 200% of the rated output current).
F 07	Fault	The AC side of the inverter is attempting to backfeed to the AC grid as a result of another fault.	The inverter has shut down for safety reasons. Manually restart the inverter. If condition persists, contact DKS Tech Support.

F 08	Warning	At least one connected battery has dropped below the ODP threshold set. Unit is still functioning, but if the low battery is not corrected in 60 seconds the warning will become a fault.	Charge batteries. Reduce AC load. or Press the ON/STANDBY switch once during the 60 second warning to temporarily disable the ODP (Over Discharge Protection).
F 08	Fault	The F 08 warning has become a fault. At least one connected battery has dropped below the ODP threshold set.	Charge batteries. or Remove all electrical devices taking power from the unit. Manually restart the inverter in Charge Mode.
F 09	Warning	Active only when ODP has been disabled. At least one connected battery has dropped below the default low battery threshold. Unit is still functioning, but if the low battery is not corrected in 30 seconds the warning will become a fault.	Charge batteries. Reduce AC load.
F 09	Fault	Active only when ODP has been disabled. The F 09 warning has become a fault. At least one connected battery has dropped below the default low battery threshold.	Charge batteries. or Remove all electrical devices taking power from the unit. Manually restart the inverter in Charge Mode.
F 10	Warning	Input voltage from a connected battery (or a combination of batteries) is too high for the inverter unit (battery voltage goes above 31 V). Unit is still functioning, but if the high battery does not self-correct in 5 seconds the warning will become a fault.	No action required, warning is in place to prevent shutdown in the event of a quick, self-corrected power surge.
F 10	Fault	The F 10 warning has become a fault. Input voltage from a connected battery (or a combination of batteries) is too high for the inverter unit (battery voltage goes above 31 V).	Measure the total equivalent battery voltage and replace or remove any that exceed the battery bank size requirements of the inverter. Manually restart the inverter.
F 11	Warning	The AC output voltage has dropped below the AC output voltage set points. Unit is still functioning, but if the low voltage does not self-correct in 120 seconds the warning will become a fault.	Reduce AC load and verify battery input voltage. If adjustment of load level does not clear the warning, then no further action is required, warning is in place to prevent shutdown in the event of a quick, self-corrected issue.
F 11	Fault	The F 11 warning has become a fault.	The inverter has shut down for safety reasons. Manually restart the inverter. If condition persists, contact DKS Tech Support.
F 12	Fault	At least one connected battery is bad (battery voltage has dropped below 8.5 V during charging.).	Check all batteries and replace faulty ones. Manually restart the inverter.
F 13	Warning	The DC output voltage has risen above the DC output voltage set points. Unit is still functioning, but if the high voltage does not self-correct in 30 seconds the warning will become a fault.	No action required, warning is in place to prevent shutdown in the event of a quick, self-corrected issue.
F 13	Fault	The F 13 warning has become a fault.	The inverter has shut down for safety reasons. Manually restart the inverter. If condition persists, contact DKS Tech Support.
F 14	Warning	At least one battery did not reach the target equalize set-point voltage during the 1 hour equalization stage. Normal inverting and charging is not affected by this warning.	Press the ON/STANDBY switch once to clear the fault. Check batteries and replace if necessary.

Error Condition	Possible Cause	Solution
Inverter will not turn on during initial power up.	Batteries are not connected or loose battery connections.	Check the batteries and cable connections.
No AC output voltage. No indicator lights on.	Inverter has been manually transitioned to OFF mode.	Press the ON/STANDBY switch to transition back to Invert Mode (only DC power present) or Charge Mode (AC and DC power present).
AC output voltage is low and the inverter turns loads ON and OFF.	Low battery.	Check the condition of the batteries and re-charge if possible. Replace batteries.
AC loads are receiving low voltage.	Loose AC output connections.	Check ALL AC output connections.
Inverter output reads incorrectly on volt meter.	Non-true RMS meter will probably not measure accurately.	Use a true RMS meter for accurate reading if necessary.
Charger is inoperative and inverter will not accept AC.	AC voltage has dropped out of tolerance. Loose AC input connections. AC pass-through breaker on the side of the inverter is open.	Check the AC voltage for proper voltage and frequency. Check ALL AC output wiring connections. Reset AC pass-through breaker.
Charger is supplying a lower charge rate.	Loose or corroded battery connections. Loose AC input connections.	Check and clean ALL DC connections. Check ALL AC output connections.
Charge mode indicator light indicates charging, but no charge is going to the batteries.	Charger AC input breaker on the side of the inverter is open.	Reset breaker.
Charge mode indicator light is ON, but loads are not receiving power.	Open AC output breakers.	If there is good AC voltage on the inverter's AC output terminal block, then check for open AC output breakers.

WIRE DIAGRAM

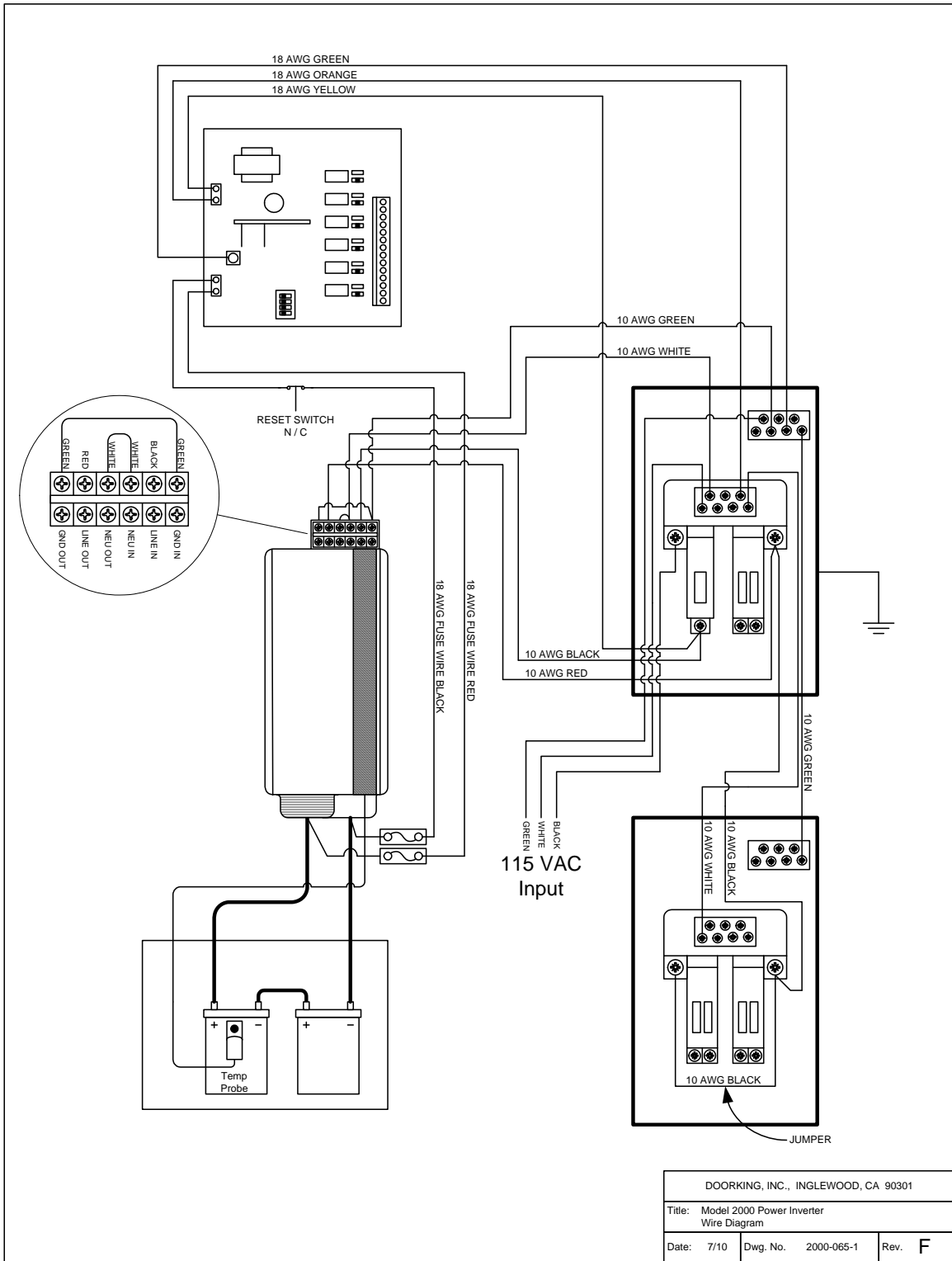

6.1 RMS VALUES, METERS and MEASUREMENT

RMS, or Root Mean Square, is the measurement used for any time varying signal's effective value: it is not an "Average" voltage and its mathematical relationship to peak voltage varies depending on the type of waveform. By definition, **RMS Value**, also called the effective or heating value of AC, is equivalent to a DC voltage that would provide the same amount of heat generation in a resistor as the AC voltage would applied to the same resistor.

Since an AC signal's voltage rises and falls with time, it takes more AC voltage to produce a given RMS voltage. In other words, the grid must produce about 169 volts peak AC that turns out to be 120 volts RMS (.707 x 169). The heating value of the voltage available is equivalent to a 120 volt DC source. (This is for example only. This does not mean that AC and DC are interchangeable!).

The typical multi-meter is not a **True RMS** reading meter. As a result it will only produce misleading voltage readings when trying to measure anything other than a DC signal or sine wave. Several types of multi-meters exist, and the owner's manual or the manufacturer should tell you which type you have. Each handles AC signals differently.

A **rectifier type** multi-meter indicates RMS values for sine waves only. It does this by measuring average voltage and multiplying by 1.11 to find RMS. Trying to use this type of meter with any waveform other than a sine wave will result in erroneous RMS readings.

Average reading digital voltmeters are just that, they measure average voltage for an AC signal. Using the equations for a sine wave (see below), average voltage (V_{avg}) can be converted to Volts RMS (V_{rms}), and doing this allows the meter to display an RMS reading for a sine wave.

A **True RMS** meter uses a complex RMS converter to read RMS for any type of AC waveform.

When taking reading with a non-True RMS reading meter, a 120 Volt RMS sine wave will still measure about 120 Volts RMS. This is because the meter uses the mathematical relationships shown below to give a proper RMS reading for a sine wave. However, if used with a modified sine wave or square wave, these meters will only read about 90-105 volts. Don't be misled, there is nothing wrong with the inverter or the meter. To prove this, try the following test. Connect a normal light bulb to the AC output and allow the inverter to power the bulb (AC source power turned off). If there is only 90-105 volts RMS available, the bulb will glow orange as it would during a brown out. If it appears normal, the voltage is approximately 120 VAC RMS. You can see that improper measurement can easily lead someone to believe that the inverter is not putting out its rated power.

Normally, True RMS reading meters are very expensive, such as the Fluke 87 series meters. However, there are now models of True RMS reading meters available on the market for under \$100.00. Check with Radio Shack for information on the True RMS meters that they carry.

A few things to keep in mind about RMS values that apply when dealing with a sine wave are as follows:

$$\text{Peak Volts AC} \times .707 = V_{rms}$$

$$V_{rms} = 1.11 \times V_{avg}$$

$$1.414 \times V_{rms} = \text{Peak Volts AC}$$

$$V_{avg} = .637 \times \text{Peak Volts AC}$$

For a modified sine wave or square wave these equations do not apply and the easiest way to deal with this is to invest in a True RMS reading meter. (For a square wave, V_{avg} , V_{rms} and V_{peak} are all equal).

6.2 BATTERY CABLE INDUCTANCE

What is Inductance?

When current passes through a conductor a magnetic field is set up around the conductor. As this magnetic field builds, it induces voltage in any conductor that is close by, and it induces voltage in the original conductor. The voltage induced in the original conductor is called self-inductance, and tends to oppose the current that produced it.

The magnitude of the self-induced voltage is proportional to the size of the loop formed by a wire. The larger the loop, the larger the self-induced voltage. The positive and negative battery cables in a system are in reality only a single circuit (wire), and so the inductance of the battery circuit depends on how the cables are physically positioned or arranged with respect to one another.

Tape Battery Cables Together to Reduce Inductance!

If battery cables are separated by a distance, they have much more inductance than if they are close together. If the two battery cables were coaxial there would be virtually no induced current flow since the magnetic fields would cancel one another. However, we don't have coaxial battery cables, but we can approximate them by taping the cables together every four to six inches. When the cables are taped together the magnetic fields around each battery cable tend to cancel each other. When cables are separated the magnetic fields add together and increase the inductance of the battery cables.

The table shows that with only a foot of distance between the battery cables the inductance almost doubles, and at four feet between cables the inductance is almost three times the inductance of cables taped together.

Distance Between Cables	Inductance in micro-henries
Taped Together	3.3
12" Separation	6.0
48" Separation	8-9

Since induced voltage in a conductor varies as the inductance times the rate of change of current in the inductor, the induced voltage may be three times greater than it would be if cables were not taped together. For more advanced readers, consider flyback effects and the induced voltage spikes can get into the thousands of volts range if the battery were suddenly removed from the circuit (worst case).

These induced voltage changes cause ripple in the battery cables and must be absorbed or filtered by the filter capacitors in the inverter. The ripple will lead to eventual premature breakdown of the filter capacitors and performance loss in the inverter. In addition to the problems mentioned, the induced current opposes the applied current (battery current), which directly causes a loss of inverter performance as greatly reduced efficiency.

Hopefully, this discussion gives you a better understanding of why battery cables should be kept short and close together. Maximum performance is the goal of any well-designed power system and the detail items such as this will help achieve this goal.

6.3 GROUNDING vs. LIGHTNING

If an electrical system has components grounded at different points in the earth (detail A), large voltage differences will exist between these grounds during a lightning strike. If this voltage appears between the AC and DC side of the inverter, it could fail. Likewise, if this voltage appears between the different components of an access control system, the components can fail.

The first step in protection is to make sure that all equipment in the system is physically grounded at the same location (detail B). This assures that there is no voltage potential between grounds in the system, which means there is no current flow through the system.

All equipment involved in the system should physically be located as close as possible to one another. This reduces the potential that is developed between the ground site and the individual components of the system during a lightning strike. This single point grounding (detail C) greatly reduces the potential for lightning damage to electrical equipment.

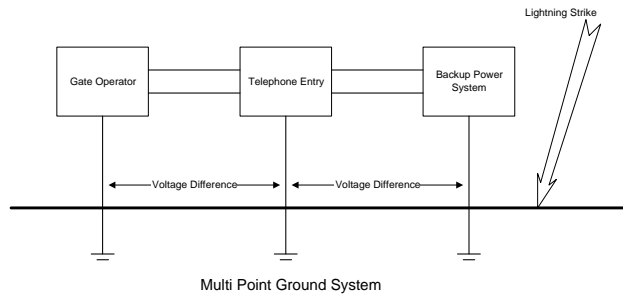

DETAIL A

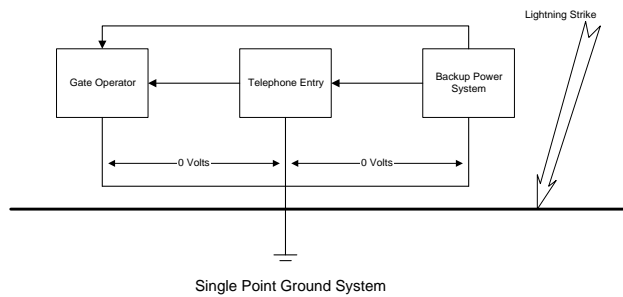

DETAIL B

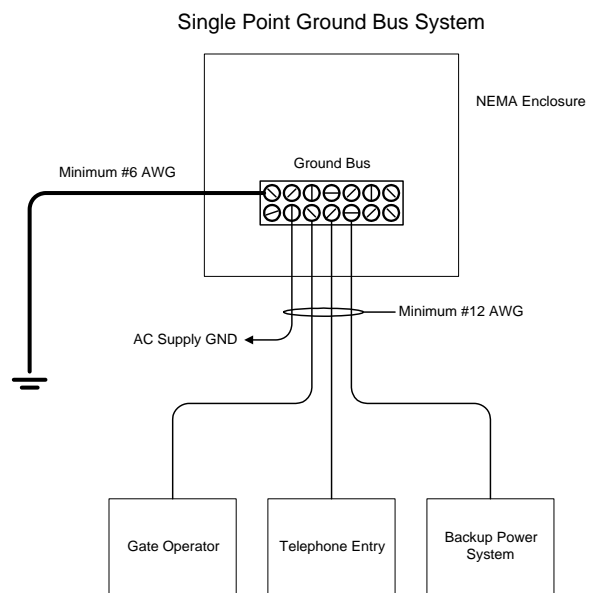

DETAIL C

LIMITED WARRANTY

DoorKing Inc. (DoorKing) warrants the Model 2000 Inverter / Power Backup System to be free from defects in material and workmanship under normal use and service for a period of two-years after the date of purchase by the original customer.

DoorKing's sole obligation under this warranty is limited to repairing or replacing, at our option, any parts which shall be determined by DoorKing to be defective, and is conditioned upon the original customer giving notice of any such defect to DoorKing within the warranty period. DoorKing reserves the sole right to make the final decision whether there is a defect in materials and/or workmanship, and whether or not the product is within the warranty period. DoorKing does not warrant its products from any and all defects: (1) arising out of material or workmanship not provided by DoorKing, or (2) resulting from abnormal use of the product or use in violation of the instruction manual, or (3) in products repaired or serviced by other than DoorKing repair facilities, or (4) in components, parts, or products expressly warranted by another manufacturer. DoorKing is not responsible for any damages or other cost proximately caused by, or which may result from installation, handling, non-recommended operation abuse, or modifications not authorized by DoorKing or for any damages which may arise out of use of the Goods.

This warranty shall not apply to any DoorKing product that has been subject to misuse, neglect, accident, improper installation or connection to an improper voltage source, or to products damaged by Acts of God (lightning strikes, power surges, floods, fire, natural disaster).

This warranty covers bench repairs only, and any repairs must be made at the factory or place designated in writing by DoorKing. Any product or parts must be returned to DoorKing, 120 Glasgow Avenue, Inglewood, CA. 90301, freight prepaid. DoorKing will pay freight on our return of repaired or replaced items in warranty. DoorKing will not be responsible for any costs incurred involving on site service calls, or for any labor charges incurred in the removal or replacement of defective parts.

THIS WARRANTY IS MADE EXPRESSLY IN LIEU OF ALL OTHER WARRANTIES, EXPRESSED OR IMPLIED, INCLUDING BUT NOT LIMITED TO WARRANTIES OF MERCHANTABILITY, MERCHANTABILITY OR FITNESS FOR A PARTICULAR PURPOSE, OR THOSE ARISING BY LAW, STATUTE, USAGE OF TRADE OR COURSE OF DEALING, AND IN LIEU OF ANY OTHER OBLIGATIONS OR LIABILITIES ON THE PART OF DOORKING. ACCORDINGLY, DOORKING ASSUMES NO LIABILITY OR OBLIGATION WHATSOEVER IN THE SALE OF THIS PRODUCT INCLUDING ANY LIABILITY FOR INCIDENTAL, CONSEQUENTIAL OR SPECIAL DAMAGES TO YOU OR ANY OTHER PERSON, PROPERTY OR ENTITY RESULTING FROM THE USE OR POSSESSION THEREOF. OUR MAXIMUM AGGREGATE LIABILITY TO YOU SHALL NOT EXCEED THE AMOUNT PAID BY YOU FOR THE PRODUCT. THE LIMITATIONS IN THIS SECTION SHALL APPLY WHETHER OR NOT THE ALLEGED BREACH OR DEFAULT IS A BREACH OF A FUNDAMENTAL CONDITION OR TERM, OR A FUNDAMENTAL BREACH. WARRANTIES IMPLIED BY LAW ARE LIMITED IN DURATION TO THE TWO-YEAR PERIOD DESCRIBED ABOVE.

This warranty gives you specific legal rights, and you may have other rights which vary from state to state. Some states do not allow limitations on how long an implied warranty lasts, and some states do not allow the exclusion or limitation of incidental or consequential damages, so the above limitations or exclusions may not apply to you.

LIFE SUPPORT POLICY

As a general policy, DoorKing, Inc. does not recommend the use of the Model 2000 Inverter / Power Backup System in life support applications where failure or malfunction of the DoorKing product can be reasonably expected to cause failure of the life support device or to significantly affect its safety or effectiveness. DoorKing, Inc. does not recommend the use of any of its products in direct patient care. DoorKing, Inc. will not knowingly sell its products for use in such applications.

Examples of devices considered to be life support devices are neonatal oxygen analyzers, nerve stimulators (whether used for anesthesia, pain relief, or other purposes), autotransfusion devices, blood pumps, defibrillators, arrhythmia detectors and alarms, pacemakers, hemodialysis systems, peritoneal dialysis systems, neonatal ventilator incubators, ventilators for both adults and infants, anesthesia ventilators, and infusion pumps as well as any other devices designated as "critical" by the U.S. FDA.

