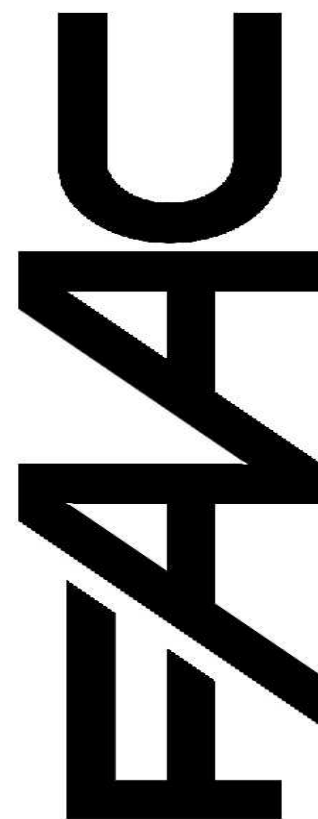

THE 402 OPERATOR AND 455 D CONTROL PANEL: INSTALLATION MANUAL

November, 2003
402 Operator And
455 D Control Panel
Installation Manual

CONTENTS

Important Safety Information	2
Technical Data	4
Unpacking the Operator	5
The 402 Compact Operator General Characteristics	6
Installation Instructions	6
Prepare the Gate	6
Manual Release Mechanism	7
Install the Operator	7
Install the 455 D Control Panel	9
Exploded View, 402 CBC	11
402 Parts List	12
The 455 D Control Panel Installation Instructions	
The 455 D Control Panel General Description	14
Installing the 455 D Control Panel	14
Connect the Main Power Supply	14
Connect the Operator to the Control Panel	15
Check the Motor's Direction of Rotation	15
Connect Other Devices	16
Set Other Operating Controls	18
Programming	20
Learning of Operating Times	22
Learning of Normal Times	22
Learning Times with Gatecoder	22
Automated Systems Test	23
Logic Tables of 455 D Control Panel	24
Maintenance	26
Safety in Gate Design	26
Troubleshooting	27
Limited Warranty	28

The logo for FAAC, consisting of the letters 'F', 'A', and 'C' stacked vertically in a bold, stylized, sans-serif font. The 'F' is the top letter, 'A' is the middle, and 'C' is the bottom. The letters are black and have a slight shadow effect.

FAAC International, Inc.
303 Lexington Avenue
Cheyenne, WY 82007
www.faacusa.com

IMPORTANT SAFETY INFORMATION

Both the installer and the owner and/or operator of this system need to read and understand this installation manual and the safety instructions supplied with other components of the gate system. This information should be retained by the owner and/or operator of the gate.

WARNING! To reduce the risk of injury or death

1. **READ AND FOLLOW ALL INSTRUCTIONS.**
2. Never let children operate or play with gate controls. Keep the remote control away from children.
3. Always keep people and objects away from the gate. **NO ONE SHOULD CROSS THE PATH OF THE MOVING GATE.**
4. Test the gate operator monthly. The gate **MUST** reverse on contact with a rigid object or stop when an object activates the non-contact sensors. After adjusting the force or the limit of travel, retest the gate operator. Failure to adjust and retest the gate operator properly can increase the risk of injury or death.
5. Use the emergency release only when the gate is not moving.
6. **KEEP GATES PROPERLY MAINTAINED.** Read the owner's manual. Have a qualified service person make repairs to gate hardware.
7. The entrance is for vehicles only. Pedestrians must use separate entrance.
8. **SAVE THESE INSTRUCTIONS.**

When installing the photo-beams supplied with this unit two things need to be considered.

1. Care should be exercised to reduce the risk of nuisance tripping, such as when a vehicle, trips the sensor while the gate is in motion.
2. One or more photobeams shall be located where the risk of entrapment exists, such as the perimeter reachable by the moving gate leaf.

GATE DESIGN

1. A gate is a potential traffic hazard, so it is important that you locate the gate far enough away from the road to eliminate the potential of traffic getting backed up. This distance is affected by the

size of the gate, how often it is used, and how fast the gate operates.

2. The operator you choose to install on your gate must be designed for the type and size of your gate and for the frequency with which you use the operator.
3. Your gate must be properly installed and must work freely in both directions before the automatic operator is installed.
4. An automatic operator should be installed on the inside of the property/fence line. Do not install the operator on the public side of the property/fence line.
5. Pedestrians should not use a vehicular gate system. Prevent such inappropriate use by installing separate gates for pedestrians.
6. Exposed, reachable pinch points on a gate are potentially hazardous and must be eliminated or guarded.
7. Outward swinging gates with automatic operators should not open into a public area.
8. The operating controls for an automatic gate must be secured to prevent the unauthorized use of those controls.
9. The controls for an automatic gate should be located far enough from the gate so that a user cannot accidentally touch the gate when operating the controls.
10. An automatic gate operator should not be installed on a gate if people can reach or extend their arms or legs through the gate. Such gates should be guarded or screened to prevent such access.

INSTALLATION

1. If you have any question about the safety of the gate operating system, do not install this operator. Consult the operator manufacturer.
2. The condition of the gate structure itself directly affects the reliability and safety of the gate operator.
3. Only qualified personnel should install this equipment. Failure to meet this requirement could cause severe injury and/or death, for which the manufacturer cannot be held responsible.
4. The installer must provide a main power switch that meets all applicable safety regulations.
5. Clearly indicate on the gate with the 2 warning signs that are included (visible from either side of the gate).

6. It is extremely unsafe to compensate for a damaged gate by increasing hydraulic pressure.
7. Devices such as reversing edges and photobeams must be installed to provide better protection for personal property and pedestrians. Install reversing devices that are appropriate to the gate design and gate application.
8. Before applying electrical power, be sure that the voltage requirements of the equipment correspond to your supply voltage. Refer to the label on your operator system.

USE

1. Use this equipment only in the capacity for which it was designed. Any use other than that stated should be considered improper and therefore dangerous.
2. When using any electrical equipment, observe some fundamental rules:
 - Do not touch the equipment with damp or humid hands or feet.

- Do not install or operate the equipment with bare feet.
 - Do not allow small children or incapable persons to use the equipment.
3. If a gate system component malfunctions, turn off the main power before making any attempt to repair it.
 4. Do not attempt to impede the movement of the gate. You may injure yourself as a result.
 5. This equipment may reach high temperatures during operation; therefore, use caution when touching the external housing of the operator.
 6. Learn to use the manual release mechanism according to the procedures found in this installation manual.
 7. Before carrying out any cleaning or maintenance operations, disconnect the equipment from the electrical supply.
 8. To guarantee the efficiency of this equipment, the manufacturer recommends that qualified personnel periodically check and maintain the equipment.

U.L. CLASS AND FAAC OPERATOR

Model	Duty Cycle	Typical Use
Class I: Residential Vehicular Gate Operator		
402 750	Limited duty	<ul style="list-style-type: none"> • Home use • Small apartment building, for example, up to 4 units in a building, with limited public access
422 760		
412 400		
620 640		
885		
Class II: Commercial/General Access Vehicular Gate Operator		
400 640	Continuous duty	<ul style="list-style-type: none"> • Apartment buildings • Very public access
620 885		
Class III: Industrial/Limited Access Vehicular Gate Operator		
400 640	Continuous duty	<ul style="list-style-type: none"> • No public access
620 885		
Class IV: Restricted Access Vehicular Gate Operator		
620 640	Continuous duty	<ul style="list-style-type: none"> • Prison rated security
885		

TECHNICAL DATA

THE 402 COMPACT OPERATOR

Parameter	402 Operator
Physical dimensions:	
Weight, lb (kg)	14-1/3 (6.5)
Length, in. (mm)	36 (914)
Width ´ height, in. (mm)	3-1/2 ´ 3-1/2 (90 ´ 90)
Motor speed, rpm	1400
90-deg opening time, sec	12
Thrust and traction force, lb (kg)	0-1100
Maximum duty cycle, motor run time	50%
Power voltage required, VAC (frequency, Hz) ¹	115 (50-60) ± 10% or 230, +6 or -10% (50-60) ¹
Current draw, amps	
115 VAC power source	2.4
220 VAC power source	1.2
Operating temperature range, deg F (deg C)	-4 to 131 (-20 to 55)
Thermal cut out, deg F (deg C)	212 (100)
Oil quantity, qt (liter)	1-1/2 (1.4)
Oil type	FAAC XD 220 or Shell/Tellus 15
Gate leaf constraints	
Maximum weight per leaf, lb (kg)	900 (410)
Maximum length per leaf, ft (m)	10 (3)

¹ Your standard 220 VAC power source meets the specification for the required power supply of 230 VAC, +6 or -10%.

UNPACKING THE OPERATOR

When you receive your 402 Compact Operator, complete the following steps.

Inspect the shipping box for physical damage such as leaking oil or a torn carton. Then inspect the operator after you remove it from the box. Notify the carrier immediately if you note any damage because the carrier must witness the damage before you can file a claim.

As you unpack the box, insure that all the parts listed below are included (see Figure 1). If you have ordered a kit (a pair of operators), you will have twice the quantity of parts listed below (except where noted), and you will also have a radio receiver and two transmitters.

- 1 Control panel box with control panel inside (only 1 per kit)
- 1 402 Operator unit

- 1 Protective cover for the operator
- 1 End cap or guard cover
- 1 Rear mounting bracket (for post or wall)
- 1 Rear mounting plate (use is optional)
- 1 2 in. (50 mm) operator pin with 1 nut for attachment to rear mounting bracket
- 1 Mounting fork support
- 1 2-3/4 in. (70 mm) operator pin with 1 self-locking nut for attachment to rear flange of operator
- 1 1-1/8 in. (29 mm) pin for fixing the front coupling to the operator's piston rod
- 2 E clips for either end of the pin fixing the front coupling to the operator's piston rod
- 1 Front mounting brackets
- 1 Nameplate (with 2 screws) for covering pressure adjustment screws
- 1 Manual Release key

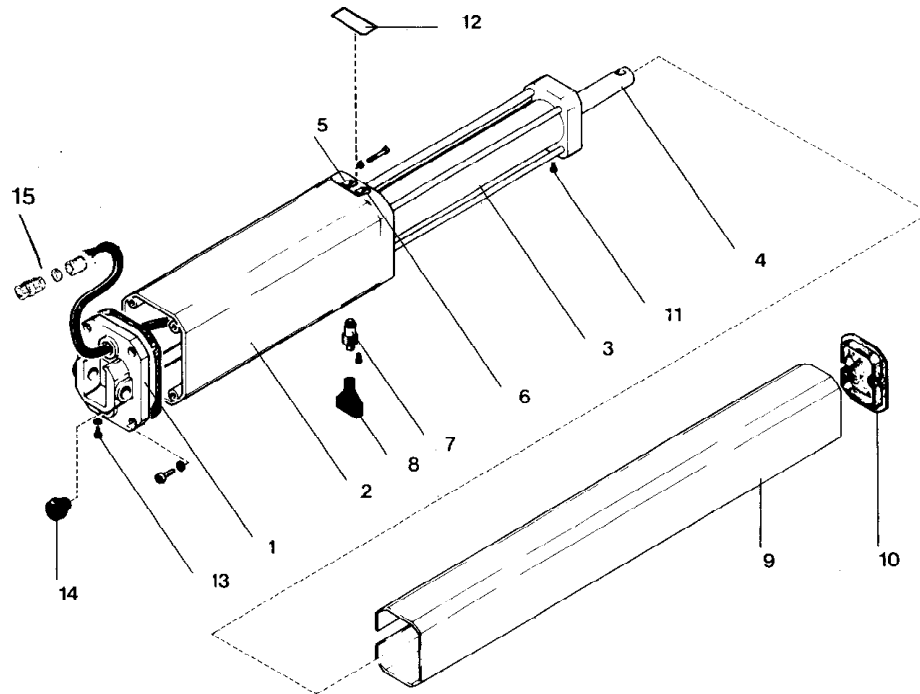

Figure 1. The 402 Compact Operator

- 1 Rear flange
- 2 Operator casing containing pump and motor
- 3 Cylinder body
- 4 Piston rod with hole for attaching to front mounting bracket
- 5 Green screw for adjusting pressure
- 6 Red screw for adjusting pressure
- 7 Manual Release Mechanism
- 8 Manual Release key
- 9 Cover
- 10 Cover end cap
- 11 Cover fixing screw (1 of 2)
- 12 Nameplate secured with screws
- 13 Oil vent screw
- 14 Oil loading cap

THE 402 COMPACT OPERATOR

GENERAL CHARACTERISTICS

The 402 Compact Operator is an automatic, light-duty gate operator it can accommodate a gate leaf up to 10 ft (3m) in length and up to 900 lbs (410 kg) in weight.

Note: The 402 Compact Operators are *not* recommended for use with solid gates.

The self contained 402 operator is an electro-hydraulic unit consisting of an electric motor, a pump, a valve assembly and a hydraulic cylinder, all housed in an anodized aluminum oil reservoir.

All models of the 402 operator have one hydraulic lock. The CBC version is designed to lock when the piston is extended. The CBA version is designed to lock when the piston is retracted.

The hydraulic lock is a service device rather than a security device. Additional external locks are recommended under the following conditions:

- Your gate leaf is 10 ft or longer.
- Your installation site requires tight security.
- Your gate site is subject to vandalism.
- Your gate site is subject to strong or very gusty wind.
- Your gate system has an open-hold-open device.

The electronic control panel is a microprocessor-based controller that accepts a range of product accessories and reversing devices to allow flexibility in designing the gate system. The 450 MPS control panel allows you to set the opening/closing time, a leaf delay for a two-

leaf gate system, the operating logic for your gate system, the pause time, the reversing stroke, and the behavior of reversing devices.

For its protection, the single phase, bi-directional electric motor shuts off automatically if its operating temperature reaches 212 deg F (100 deg C). Also for the protection and proper operation of the 402 operator, each gate leaf on which it is installed must have a fixed positive stop in both the open and closed positions.

The 402 Operator also includes a triangular key operated Manual Release Mechanism and two bypass valves which precisely control the force applied to the gate leave(s). The Manual Release Mechanism is a key operated device that disengages or engages the hydraulic system of the 402 Operator. When the hydraulic system is disengaged, you can open and close the gate leaf by hand. Such manual operation of the gate leaf is necessary during installation and useful during power failures.

The two bypass valves located on the top of the operator needs to be adjusted to meet the safety standards of FAAC International, Inc. The standards state the gate leaf should stop, if it encounters a force greater than 33 lbs. (15 kg). Once the pressures are adjusted, the by pass valve screws are covered so that the pressures are not altered.

Additional reversing devices such as photobeams or reversing edges should be installed to provide more complete safety for people and property.

The electronic control panel is a microprocessor-based controller that accepts a wide range of product accessories and reversing devices. Thus allowing for flexible gate system design.

INSTALLATION INSTRUCTIONS

Installing the 402 Compact Operator involves preparing the gate, installing the operator(s), installing the control panel, and fine-tuning the pressure adjustments on the operator(s).

Note: The following installation instructions assume you are fully capable of installing an operator. This manual does not instruct you in designing a gate, installing a gate, or basic electrical wiring. The installation tasks discussed in this manual are tasks peculiar to the 402 Operator.

PREPARING THE GATE

Before installing the 402 Operator, you need to prepare the gate itself for the operator. Be sure to do the following things:

1. Make sure that the gate is plumb.
2. Make sure that the gate moves smoothly on its hinges without excessive friction by swinging it open and closed by hand. Lubricate all the gates' moving parts.
3. Provide positive stops for the gate leaves in the fully open and fully closed positions (see Figure 2).

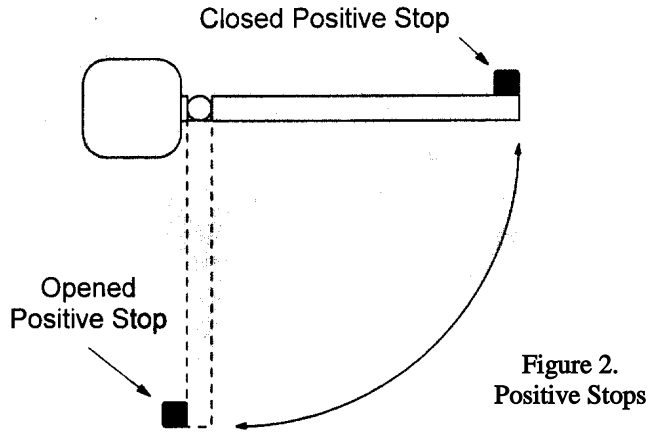

Figure 2.
Positive Stops

MANUAL RELEASE MECHANISM

Insert the key and turn it counterclockwise one full turn to disengage the operator's hydraulic system (see Figure 3). You can now move the gate leaf slowly by hand to open or close the gate.

Operating the gate leaf by hand is necessary during installation and is useful during power failures.

You re-engage the hydraulic system by turning the key clockwise one full turn.

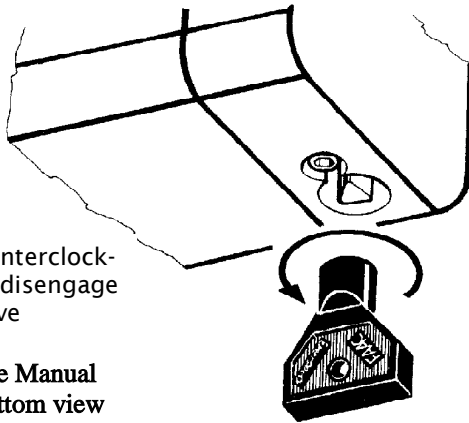

Turn the key counterclockwise 1/2 turn to disengage the hydraulic drive

Figure 3. The Manual
Release key, bottom view

INSTALLING THE OPERATOR

Installing the model 402 operator consists of the following steps:

1. Attaching the rear mounting bracket
2. Attaching the operator to the rear mounting bracket
3. Attaching the front mounting bracket to the operator
4. Attaching the operator to the gate leaf
5. Adjusting the hydraulic pressures for the operator

ATTACH THE REAR MOUNTING BRACKET

Attach the rear mounting bracket according to the dimensions in Figure 4.

WARNING! You must achieve the A and B dimensions, dimensions as specified in Figure 4. Modification of the rear bracket may be necessary to achieve these dimensions (i.e., cutting or extending the bracket provided)

If you have a steel gate post, weld the rear bracket directly to it. If the gate post is made of any other material, attach the optional mounting plate, with lag bolts or anchors, and weld the bracket to it.

For an outward swing gate refer to Figure 5.

ATTACH THE MOUNTING HARDWARE

Place the operator so that the red and green pressure adjusting screws face up. Place the mounting fork (hex cut up if you have a nylon rear fork) in the operator's rear flange, secure with the long brass pin and self-locking nut.

Attach the fork assembly to the rear mounting bracket and secure with the short pin, washer, and nut.

Push the front pin through the front mounting bracket then the piston rod to temporarily attach them together.

ATTACH THE FRONT MOUNTING BRACKET TO THE OPERATOR

Insert the triangular key over the Manual Release mechanism on the underside of the operator and turn the key counterclockwise one turn.

For inward swing, pull the piston completely out and push it back inward approximately 1/4" (6mm).

For outward swing, push the piston in completely and pull it back out approximately 1/4" (6mm).

NOTE: Be sure the operator is level and that the gate is against the closed positive stop.

Hold the front mounting bracket flush against the gate, mark the location of the front mounting bracket, remove the operator from the gate. Remove the front mounting bracket from the piston rod.

NOTE: Clamping the front mounting bracket at the marked location before checking the swing,

as instructed below, will ensure proper location of the front mounting bracket.

Bolt or weld the front mounting bracket to the marked location on the gate.

WARNING! Do Not Weld the front mounting bracket with the operator attached. Doing so will seriously damage the operator.

ATTACH THE OPERATOR TO THE GATE

Re-attach the operator to the mounting brackets. Once the operator is mounted and level, remove the vent screw from the bottom of the valve body. Use a 3mm hex wrench.

WARNING! Failure to remove the vent screw may result in erratic operation of the operator or blown seals.

Slowly move the gate open and close.

WARNING! The piston should not bottom out in either direction. Doing so will seriously damage the operator.

Be sure that the gate reaches the positive stop before the piston bottoms out. After checking the swing of the gate, secure all nuts and bolts.

Once the operator is secure, install the protective cover over the piston of the operator, first insert the two spacers (items labeled 2 in Figure 6) in the front flange of the operator as shown. The spacers dampen any vibrations to the operator.

Next, slip the cover over the operator. The slit in the cover should face the gate, and the cover should be placed firmly over the rear of the operator cover (item 1 in the figure).

Finally, use the black plastic screws (items 3 and 4) to fix the cover to the operator and the end cap (item 5).

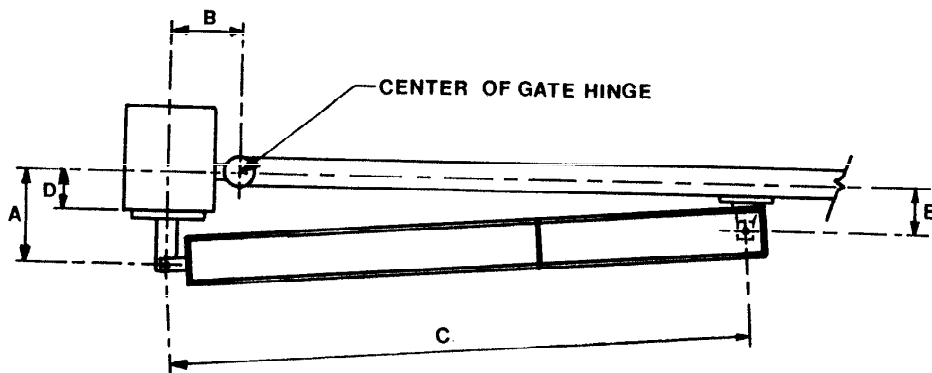

Figure 4. An inward swinging gate, top view: important mounting dimensions

402 Standard	
A	4-1/2 in. (114 mm)
B	4-1/2 in. (114 mm)
C	35-1/2 in. (902 mm)
D	If greater than 2 in. (50 mm), construct a recess liner.
E	Must be less than A

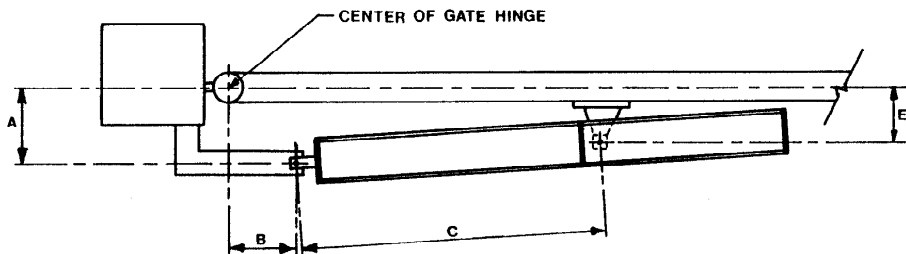
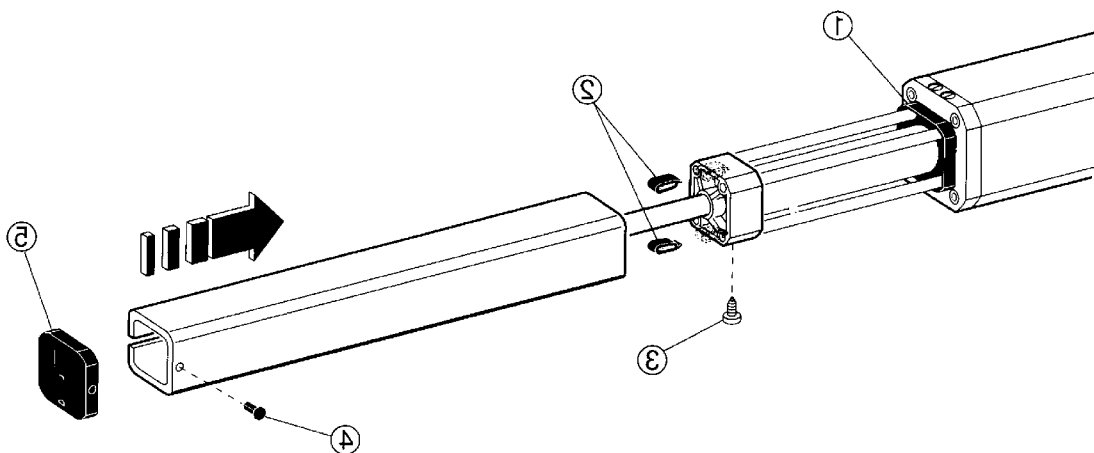

Figure 5. An outward swinging gate, top view: important mounting dimensions

402 Standard	
A	4-1/2 in. (114 mm)
B	4-1/2 in. (114 mm)
C	26-1/2 in. (673 mm)
E	Must be less than A

Figure 6. Install the cover for the 402 Operator



INSTALLING THE 455 D CONTROL PANEL

Locate the control panel in the most convenient position possible, considering the movement of the gate. Figure 6 shows a basic layout for a two-leaf gate with the 402 Compact Operator.

Installing the control panel consists of the following general steps:

- Connecting the main power to the control panel
- Connecting the activating device
- Connecting the operator to the control panel
- Checking the direction of the motor's rotation
- Connecting other devices to the control panel
- Set operating modes

The installer is responsible for grounding the gate and operator systems, for providing the main power breaker switch, and for making sure that the entire gate system meets all applicable electrical codes.

For the complete 455 D Control Panel Installation Instructions, see pages 14—25 of this manual.

Figure 7. The layout of a sample gate system

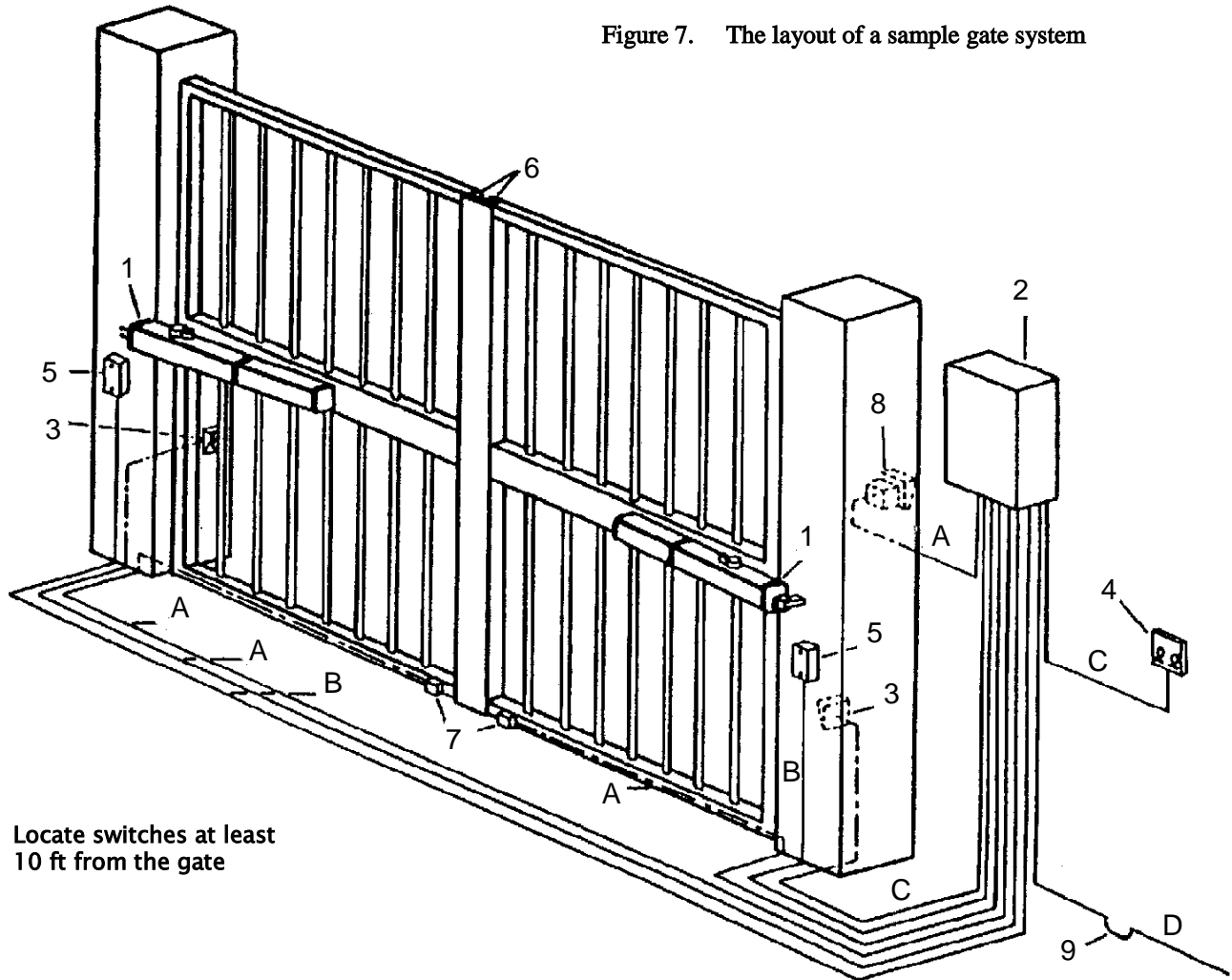

Locate switches at least
 10 ft from the gate

- 1 Operator
- 2 Control Panel
- 3 Photocell
- 4 Switch
- 5 Junction box (see text)
- 6 Reversing edges
- 7 Gate stops
- 8 Switch
- 9 Wiring to main circuit breaker

Wire Gauges for Given Voltage

220 VAC

- A 2 × 18 AWG
- B 4 × 14 AWG
- C 5 × 18 AWG
- D 4 × 14 AWG up to 414 ft

115 VAC

- A 2 × 18 AWG
- B 4 × 14 AWG
- C 5 × 18 AWG
- D 3 × 14 AWG up to 130 ft
 3 × 10 AWG up to 340 ft

EXPLODED VIEW, 402 CBC

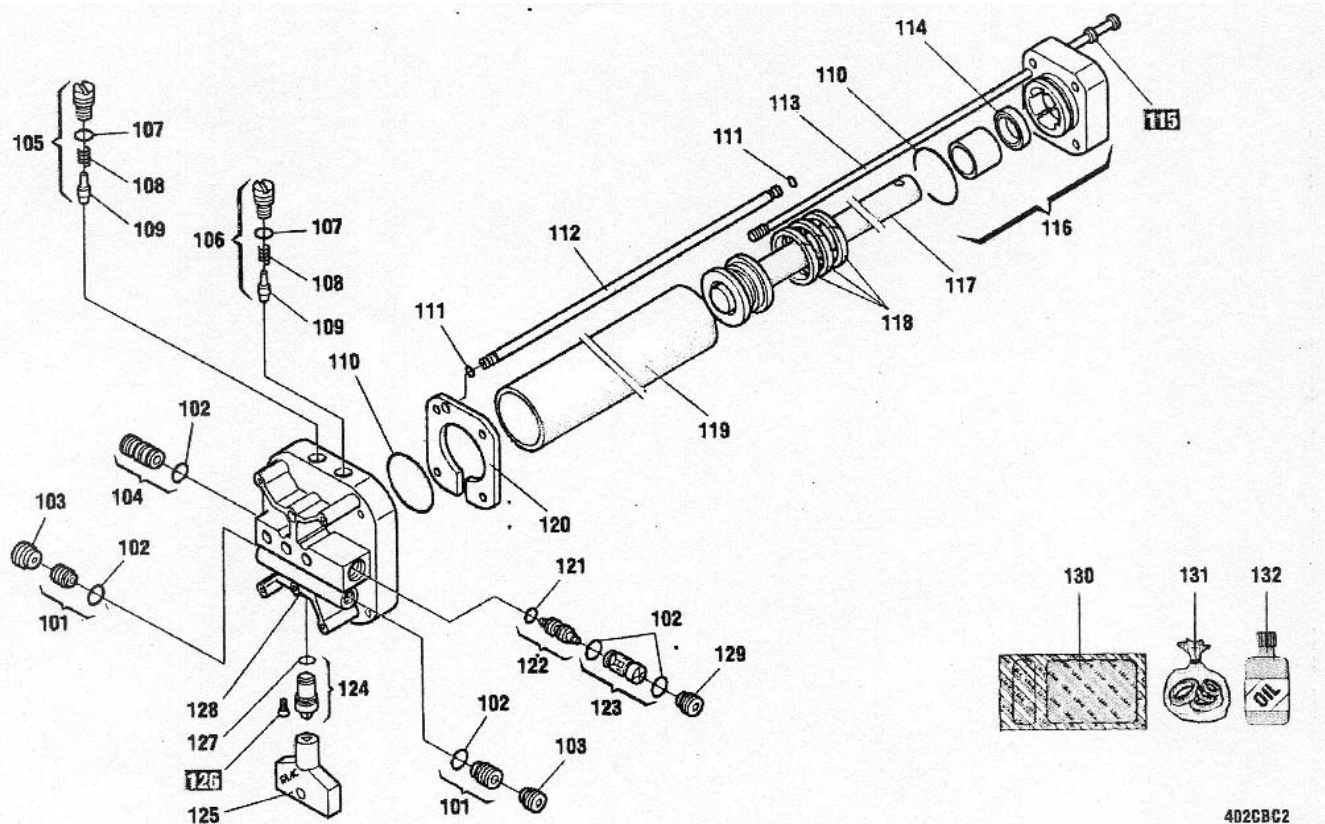
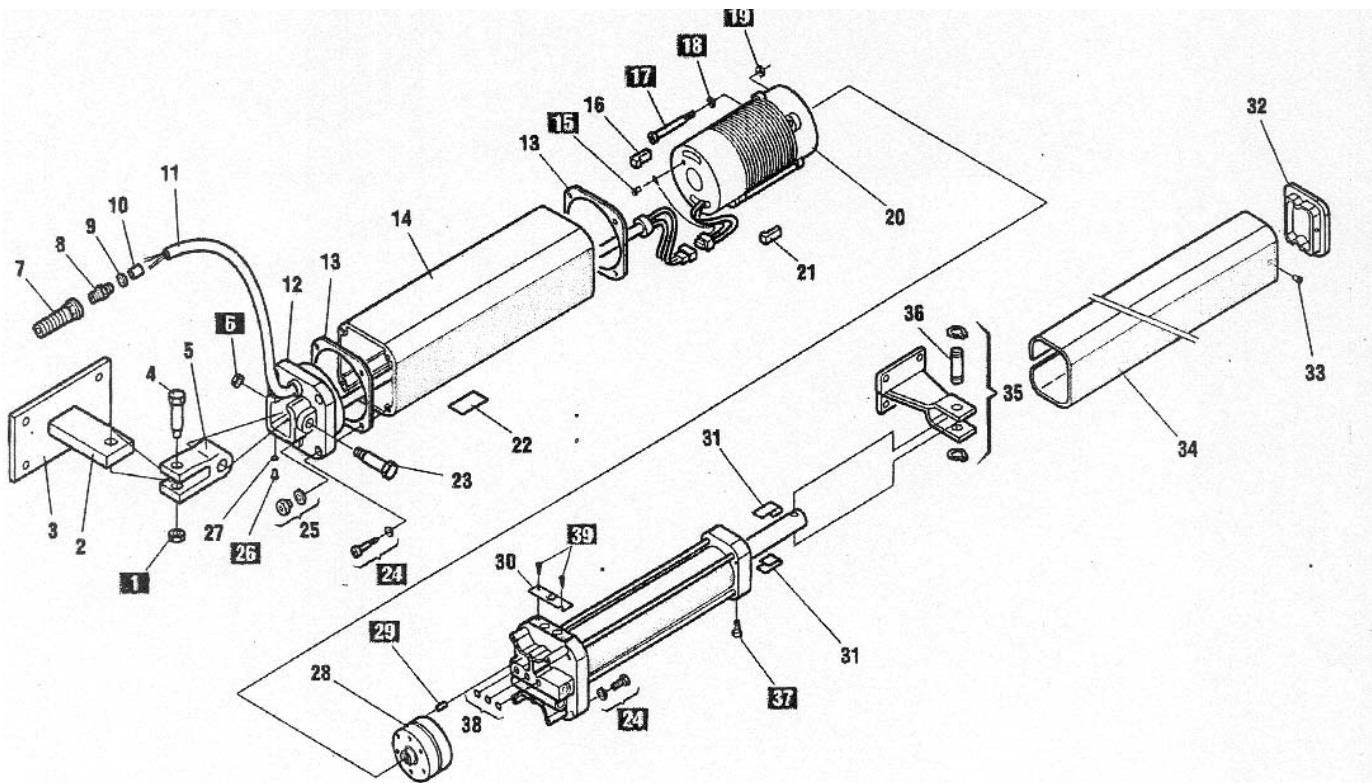

402 PARTS LIST

POS	PART NO.	DESCRIPTION	QTY
1	2036	Galvanized Nut (8mm)	1
2	7220015	Rear Bracket	1
3	7284005	Rear Bracket Plate	1
4	7182075	Short Pin	1
5	7221115	Rear Fork	1
6	2037	Self-Locking Nut (8mm)	1
7*	7109145	Strain Relief	1
8*	7109155	Strain Relief Nut	1
9*	7039305	Strain Relief Brass Washer	1
10*	2581	Fiber Washer	1
11	7514055	Electric Power Cord	1
12	7170435	Rear Flange	1
13	7099101	Gasket (D80)	2
14	7450005	Operator Body	1
15	N/A	Self-Threading Screw	1
16	7119475	Silent Block	2
17	2365	Motor Bolt (4mmX50)	4
18	2366	Lock Washer	4
19	2367	Hex Nut (4mm)	4
20**	77000425	115V 1400 RPM Motor	1
21	7119485	Vibration Dampener	2
22	N/A	Vent Screw Label	1
23	7182175	Long Pin	1
24	N/A	Socket Head Screw (5X20mm)	8
25	7110015	Plug (Oil)	1
26	2274	Vent Screw (4x6mm)	1
27	7094065	Gasket (Copper)	1
28	3204395	1 Lt Lobe Pump	1
29	N/A	Pump Pin	2
30	7203275	By-Pass Protection Cover	1
31	760285	Spacers (Protective Cover)	2
32	7271545	Protective Cover End Cap	1
33	7114025	Protective Cover Plug	1
34	7272085	Protective Cover	1
35	4304015	Front Mounting Bracket	1
36	7182355	Pin Front Bracket	1
37	N/A	Black Plastic Screw	1
38	7090010015	O-Ring (3)	3
39	N/A	Stainless Steel Screw (2.9mm x 6.5mm)	2

POS	PART NO.	DESCRIPTION	QTY
101	4404065	Inlet Valve	2
102	N/A	O-Ring	5
103	7049135	Valve Retainer	2
104	4180205	Blank Lock Valve	1
105***	4180135	Green By-Pass Valve	1
106***	4181045	Red By-Pass Valve	1
107	7090150	O-Ring (By-Pass Valve)	2
108	7210025	By-Pass Spring	2
109	7119335	By-Pass Seat	2
110	7090350	O-Ring (Front Flange)	2
111	7090665	O-Ring (Alum Retract Tube)	2
112	7361315	Retract Tube (Alum)	1
113	7230225	Tie-Rod (Cylinder)	4
114	N/A	O-Ring (Front Flange Internal)	1
115	N/A	Star Washer	4
116	4994165	Front Flange	1
117	4350065	Piston Assembly	1
118	7095035	Piston Rod Packing	1
119	7366065	Cylinder	1
120	7271555	Protective Cover Guide	1
121	7090300	O-Ring (Shuttle Piston)	1
122	4180285	Shuttle Piston	1
123	4404085	Lock Valve	1
124	4180355	Manual Release	1
125	713002	Triangular Release Key	1
126	N/A	Galvanized Screw	1
127	709069	O-Ring (Manual Release)	1
128	4994365	Valve Body (CBC)	1
129	7049005	Brass Retainer	1
130	3905235	Skin Pack	1
131	2168*	Seal Kit	1
132	6105	1 Qt. Monolec Oil	1

* Included in Kit #2167A*

* * 220V 1400RPM Motor Part #77000415

* ** Items include item #107, 108, and 109 in a kit

THE 455 D
CONTROL PANEL:
INSTALLATION MANUAL
PAGES 14— 25

THE 455 D CONTROL PANEL

GENERAL DESCRIPTION

The FAAC 455 D control panel is used to operate the following models.

Swing gate operators:	
400	412
402	750
422	760
Barrier gate operators:	
610/615	

The 455 D programming controls the following:

Operating logic: A, S, E, EP, B, and C logics available.

Reversing device behavior: Choose whether a triggered reversing device during closing immediately reverses gate movement or stops the gate and reverses gate movement when no longer triggered.

Torque or Pressure: Force adjustment for the 412 operator. Adjustable from 0 to 50.

Caution: For all hydraulic operators, the torque **must** be programmed to the maximum (50) setting.

Pause time between opening and closing: adjustable from 0 to 240 seconds.

Opening/Closing time: adjustable from 0 to 120 seconds.

Leaf delay on closing: adjustable from 0 to 28 seconds.

The 455 D control panel should be installed in an enclosure that is conveniently located as close as possible to the gate operator. All electrical connections from the control panel to the operator must be made in a weatherproof junction box.

The 455 D control panel requires a single-phase power supply voltage (115 VAC [$\pm 10\%$] or 230 VAC [$+6$ or -10%], 50–60 Hz). The power supply should be protected by a 15 amp dedicated circuit breaker (not provided).

The installer is responsible for grounding the operator system, for providing the main power breaker switch,

and for making sure that the entire gate system meets all applicable electrical codes. The installer should refer to the installation manual for a given operator for more information.

NOTE: An installation is U.L. compliant only when you install the FAAC operators according to the UL325 standards.

INSTALLING THE 455 D CONTROL PANEL

Locate the control panel in the most convenient position possible, considering the movement of the gate.

Installing the control panel consists of the following general steps:

- Connecting the main power to the control panel
- Connecting the activating device
- Connecting the operator to the control panel
- Checking the direction of the motor's rotation
- Connecting other devices to the control panel
- Set operating modes

CONNECT THE MAIN POWER SUPPLY

WARNING! Turn the main power off before you make any electrical connections or before programming.

Wire the main power supply to control panel terminals in block J3 (see Figures 9 and 11). The installer is responsible for insuring that a separate, grounded circuit protected by a circuit breaker is between the control panel and the main power supply. All wiring should conform to applicable electrical codes, and all wiring and fittings should be weatherproof and/or suitable for burial.

Connect the ground to the grounding terminal in block J3 and connect the power wires to the terminals labeled N (neutral) and L (line).

NOTE: For a 230V system, a neutral is not needed. Connect one 115V line to the L (Line) and a second 115V line to the N (Neutral).

CONNECT THE OPERATOR(S) TO THE CONTROL PANEL

WARNING! Turn the main power off before you make any electrical connections or before programming.

CAUTION: The operators are grounded only by the grounded circuit the installer provides.

USING A JUNCTION BOX

If an operator is more than 2 ft away from the control panel, you must use a junction box for connection. Use a U. L. Listed cord grip where the operator cord enters the junction box.

Note: If you have a one-leaf gate design, the operator **must** be connected to Motor 1 (terminals 1,2, & 3)

To wire up motor 1, connect the white wire to terminal 1(on the J4 terminal strip), the black wire to 2, and the red wire to 3. Wire each leg of the capacitor (supplied) to terminals 2 & 3.

Note: If you want to delay the closing of one gate leaf in a two-leaf gate design, be sure to connect its operator to Motor 1.

In order to wire motor 2 in a bi-parting system,

connect the white wire to terminal 4 (on the J4 terminal strip), the black wire to 5, the red wire to 6. Wire each leg of the capacitor (supplied) to terminals 5 & 6.

CHECK THE MOTOR'S DIRECTION OF ROTATION

WARNING! The pressure valves are not preset at the factory and may operate a gate leaf with enough force to endanger people and seriously damage the gate leaf itself.

After you have connected the main power supply, and the operator(s) to the control panel, you need to check the direction of rotation for each operator motor in your gate design.

Note: To check a motor's direction of rotation, you must have three closed circuits on terminal block J1. Install one circuit between terminals 11 and 16, another circuit between terminals 12 and 19, and another circuit between terminals 13 and 19.

Figure 8. The 455 D Control Panel

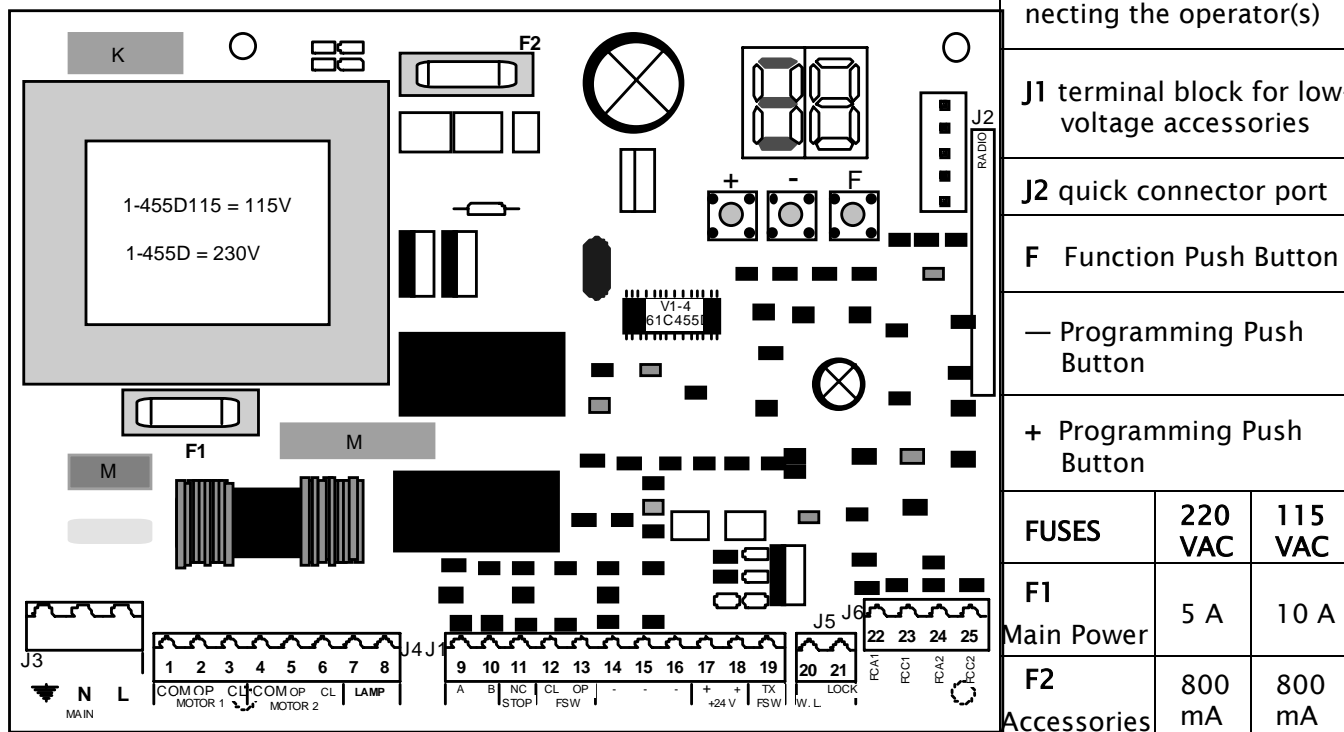

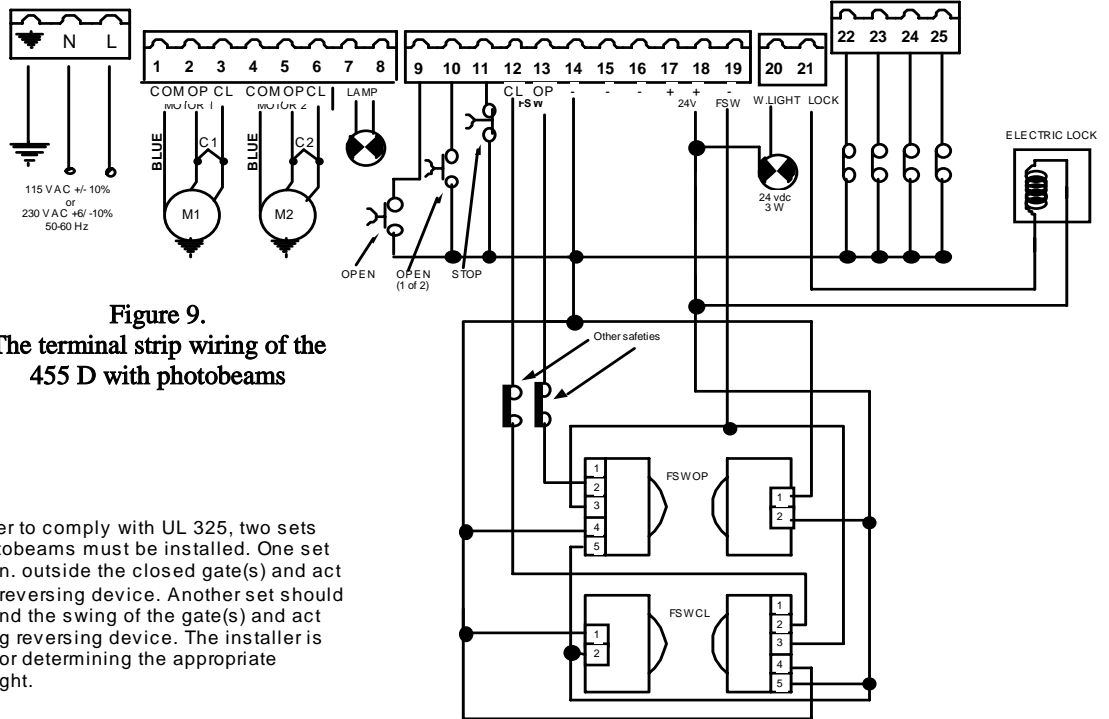

Figure 9.
The terminal strip wiring of the
455 D with photobeams

NOTE: In order to comply with UL 325, two sets of FAAC photobeams must be installed. One set should be 6 in. outside the closed gate(s) and act as a closing reversing device. Another set should be 6 in. beyond the swing of the gate(s) and act as an opening reversing device. The installer is responsible for determining the appropriate mounting height.

You cannot check the motor's direction of rotation without these circuits (jumpers) or the accessories. When properly prepared for testing, the LEDs FSWOP, STOP, and FSWCL should be illuminated (see figure 11 on page 17).

WARNING! Running the operator—even for testing purposes—without a connected reversing device is potentially dangerous. Do not place yourself within the path of the moving gate during your test.

Disengage the operator(s) with the Manual Release key (see operator installation manual), and open the gate by hand about halfway. Next, engage the operator(s) with the Manual Release key so that you can check the rotation of the motor (s).

To activate the operator(s) momentarily short across terminals 9 and 14.

Turn on the main power and send an activating signal to the operator. The gate leaf (or leaves) should open. If a gate leaf closes, then you need to turn off the main power and reverse the connection of the red and black wires on terminal block J4 for the operator controlling that leaf. Then you need to recheck the rotation direction again.

After having completed your test of the motor's direction of rotation, replace any test circuits you installed (between terminals 11 and 16, between 12 and 19, and between 13 and 19) with the proper reversing and stop devices. The instructions for installing such accessories follow.

CONNECT OTHER DEVICES

WARNING! Turn the main power off before you make any electrical connections.

POWER SUPPLY FOR ACCESSORIES: You can access a 24 VDC output for supplying power to accessories through terminals 17 or 18, (+) and 14 or 15 or 16, (-) on terminal block J1. In most cases, this source can be used to power 24 VDC accessories.

NOTE: The 455 D control panel allows a maximum accessory load of 800 mA.

REVERSING DEVICES: Reversing devices include photocells, inductive loops, and so forth. All of the reversing devices should have contacts of the normally closed (N.C.) type. Where you connect a device depends on whether you want the device to operate during opening or during closing.

NOTE: UL **does not** recognize the FAAC system with loop detectors or safety edges. FAAC photobeams must be used to comply with UL 325.

To wire photobeams, refer to page 19 (see FSWOP for opening photobeams, and FSWCL for closing photobeams). Photobeams must be connected as shown. See also page 19 for the wiring of inductive loops. If using more than one reversing device, they must be wired in series.

(a) To the U. L. Listed gate operator

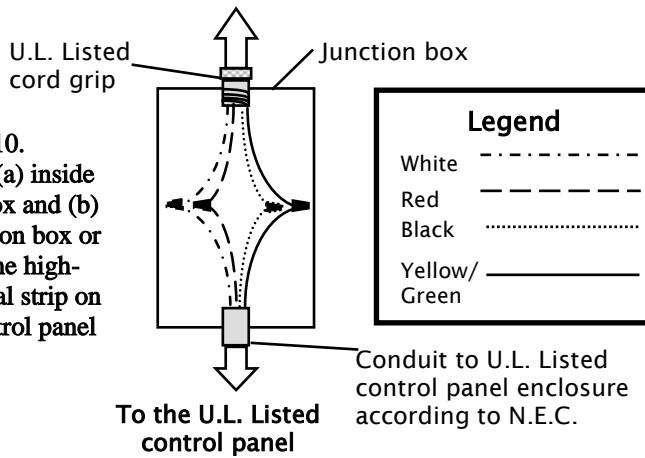
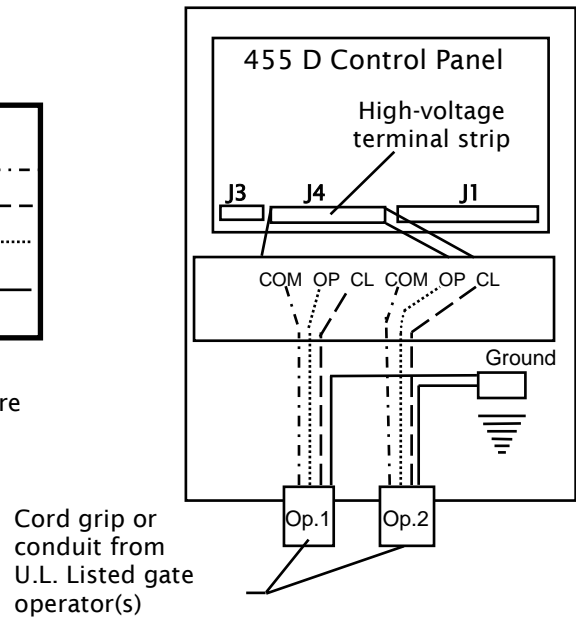

Figure 10. Wiring detail (a) inside the junction box and (b) from the junction box or operator to the high-voltage terminal strip on the 455 D control panel

(b) U.L. Listed Control Panel Enclosure



ACTIVATING DEVICES AND RADIO RECEIVER: The activating devices and radio receiver for your gate must have normally open (N.O.) contacts. Connect such devices to terminals 9 and 14.

NOTE: The FAAC radio receiver plugs into the 5 prongs labeled J2 (Quick connect port).

Page 19 shows how to connect a three or four wire receiver.

DECODER CARD: If you are installing the Digicard magnetic card reader, or the Digikey keyboard, use the quick-fit connector J2 for the DS decoder card (see Figure 8).

NOTE: If your using both a receiver and decoder, hard wire the decoder and plug in the receiver.

OPEN/HOLD OPEN DEVICE: To open and hold open the gate, simply maintain a contact across terminals 9 and 14. ("A" Mode only)

STOP BUTTON: The stop button you install must have normally closed (N.C.) contacts. Multiple stop buttons must be wired in series. Connect your stop device between terminals 11 and 16.

NOTE: The 455 D will not operate the motors without a closed circuit between 11 & 16.

The LED Indicators: The nine light emitting diodes (LEDs) on the control panel can be used to check for the proper function of the devices attached to the panel. The LED lights are on whenever the contacts are closed across each of the respective terminals.

OP_A and OP_B (Partial Opening) should illuminate only when an activating signal is sent for 2 and 1 gate leaves, respectively. STOP should be illuminated except when the stop button is pressed. FSWOP and FSWCL should be illuminated except when the reversing devices, for

LED	On	Off
OP_A	Command Given	No Command
OP_B	Command Given	No Command
Stop	No Command	Command Given
FSW Open	Opening reversing devices clear	Reversing device triggered
FSW Close	Closing reversing devices clear	Reversing device triggered
FCA1 FCC1	Flashes when gate coder is in use. Operator 1	
FCA2 FCC2	Flashes when gate coder is in use. Operator 2	

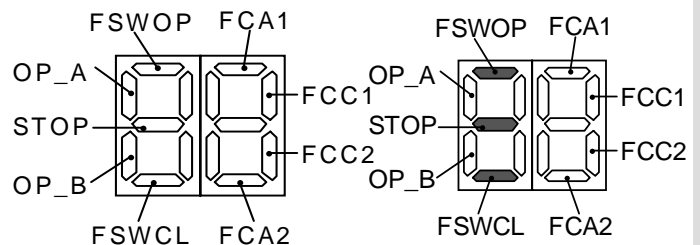

This display shows the meaning of each LED.

This display shows the normal status of the control panel.

Figure 11. The 455 D display.

opening and closing, respectively, are triggered. Use the LEDs and the next table to determine if the accessory devices you have installed are operating properly.

Electric Locks: An electric lock can be wired to the 455 D in terminals 18 and 21 (12Vac pulsed provided). If a reversing stroke is needed to allow the electric lock to release, this must be done in advanced programming.

See page 19 for the connections for a magnetic locking device.

WARNING LIGHT: Connect a warning light to terminals 18 and 20 in the group labeled *W.LIGHT* in terminal block J1 and J5. The terminals provide an output voltage of 24 VDC, maximum power 3 Watts. This output voltage will power most 24 VDC warning lights.

NOTE: The behavior of the warning light varies according to the logic you have set.

LOGICS A, S, E, EP, AND B: The warning light is on steadily during opening and the pause phase. During closing, the light flashes.

LOGIC C: The warning light is on steadily during opening and flashes during closing.

SET OTHER OPERATING CONTROLS

WARNING! Turn the main power off before you make any electrical connections.

You need to program the control panel for your gate's operation. The 455 D Control Panel has on board programming that controls a wide range of functions.

OPERATING LOGICS

NOTE: The 455 D Control Panel provides inputs for opening reversing devices and closing reversing devices. FAAC strongly recommends the use of reversing devices, such as photocells or other non-contact sensors.

- **A (automatic):** The gate opens on command and automatically closes after a pause phase. A second command while opening is ignored; a second command during the pause phase interrupts the pause time; a second command during closing reopens the gate. A maintained open command will hold the gate open.
- **S (security):** The security mode is like A logic except that a second command during opening immediately closes the gate. A maintained open command will not hold the gate open.

- **E (semi-automatic):** This mode requires a command to open and a command to close. A second command during opening stops the gate. A second command during closing reopens the gate.
- **EP (semi-automatic, step by step):** This mode requires a command to open and a command to close. A second command during opening or closing causes the gate to stop. A third command then reverses the previous motion of the gate.
- **B (manned, pulsed):** This mode is designed for guard station use and requires a three-button switch (pulsed) to open, close, and stop the gate.
- **C (manned and constant):** This mode requires constant pressure switches. One to open and one to close. No pressure on a switch stops the gate.

The three programming push buttons allow the programming of the torque (or pressure), the pause time between opening and closing, and the leaf delay on closing.

WARNING! Turn the main power off before you make any electrical connections.

For all FAAC hydraulic operators using the 455 D control panel, the force **must** be set at its maximum setting of 50 in order to supply the correct voltage to the operator.

PAUSE TIME: The pause time between opening and closing can be adjusted from 0 seconds to 4 minutes. Time is adjusted in one-second increments from 0—59 seconds. When 60 seconds is reached, time is adjusted in 10 second increments up to 4 minutes. i.e. if display shows 2.5, it means 2 minutes and 50 seconds.

LEAF DELAY: You may choose to delay one leaf on closing for overlapping gate leaves. Be sure the operator on the leaf for delayed closing is connected to Motor 1. On opening, the leaf connected to Motor 2 is delayed 2.5 sec.

NOTE: If an opening leaf delay is desired, it must be enabled in the Advance Programming. However, if enabled, you cannot *adjust* this opening delay of the operator connected to Motor 2.

The closing leaf-delay time is adjustable from 0 to 4 minutes.

NOTE: If the opening/closing time is set at less than the leaf delay time, the delayed leaf closes at the end of the closing time.

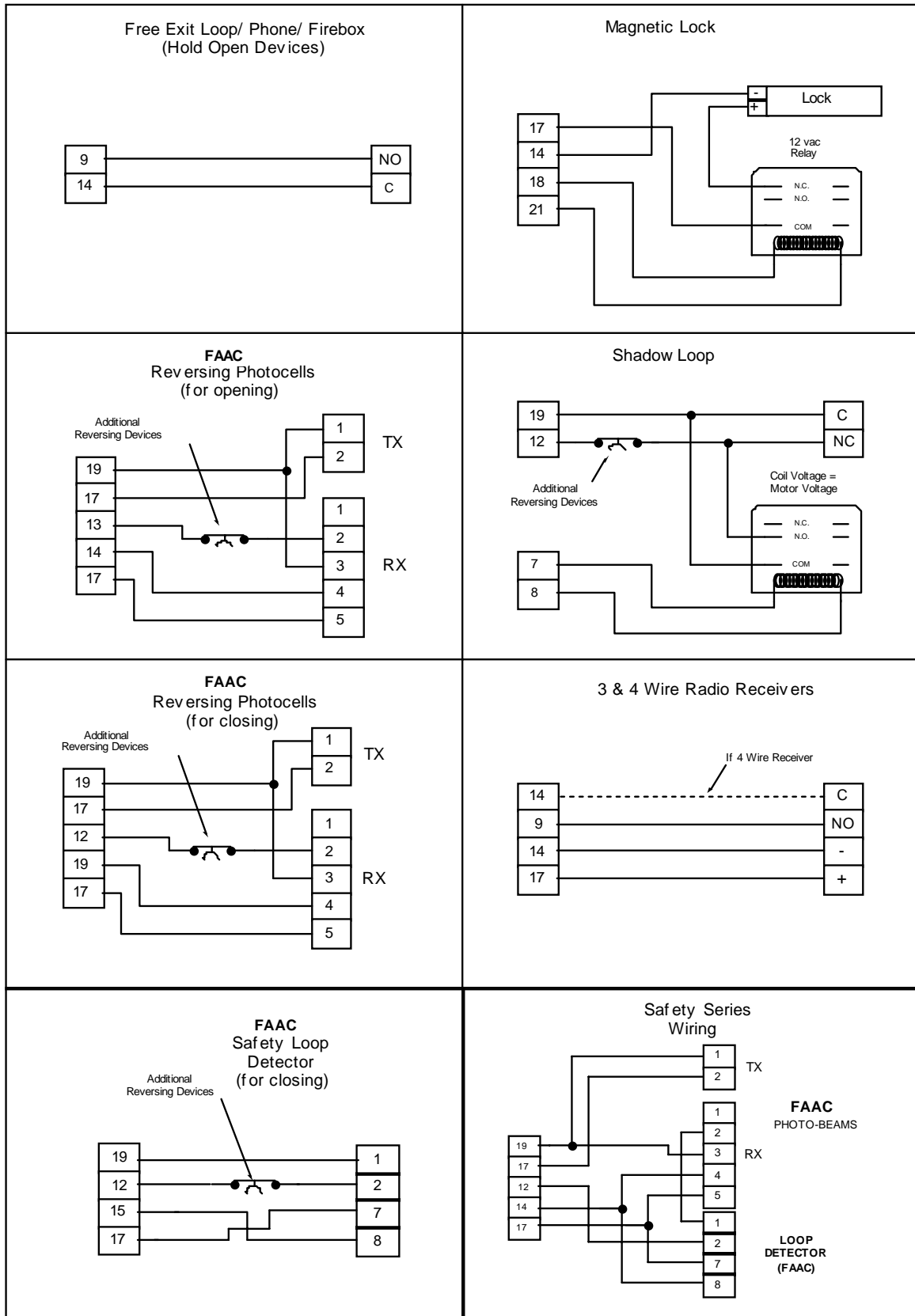

NO = Normally Open, NC = Normally Closed, C = Common, TX = Transmitter, RX = Receiver

Figure 12. Common Accessories wired to 455 D Control Panel

PROGRAMMING

To program the automated system, the "Programming Mode" must be accessed.

Programming is split into two parts: BASIC and ADVANCED.

BASIC PROGRAMMING

To access BASIC PROGRAMMING, press the "F" key.

- If you press it (and hold it down), the display shows the name of the first function.
- If you release the key, the display shows the value of the function that can be modified with keys + and - .
- If you press and hold down the "F" key again (and hold it down), the display shows the name of the next function, etc.
- When you reach the last function, press "F" to exit the program, and the display resumes showing the status of the inputs.

The table on the right shows the sequence of functions accessible in BASIC PROGRAMMING.



ADVANCED PROGRAMMING

To access ADVANCED PROGRAMMING, press the "F" key and, as you hold it down, press the "+" key:

- If you release the "+", the display indicates the name of the first function.
- If you release the "F" key, too, the display shows the value of the function that can be modified with keys "+" and "-".
- If you press the "F" key (and hold it down), the display shows the name of the next function, and if you release it, the value that can be modified with keys "+" and "-".
- When you reach the last function, press the "F" key to exit the program, and the display resumes showing the status of the inputs.

The table on page 9 shows the sequence of functions accessible in ADVANCED

PROGRAM BUTTONS		
+	-	F
LEFT	MIDDLE	RIGHT

BASIC PROGRAMMING		
Display	Function	Default
LO	OPERATING LOGICS A = Automatic (Timer to Close) E = Semi Automatic S = Security EP = (Semi-Automatic) Step by Step B = Manned, Pulsed C = Manned, constant	E
PA	PAUSE TIME This is the time between open and closing and is adjustable from 0 to 4 min. This is only true in "A" Mode. (see pause time description)	0
F1	FORCE/TORQUE MOTOR 1 This adjusts the force / torque that motor 1 is applying to the gate leaf. Setting is 0 to 50.*	25
F2	FORCE/TORQUE MOTOR 2 This adjusts the force / torque that motor 2 is applying to the gate leaf. Setting is 0 to 50.*	25
cd	CLOSING LEAF DELAY Delays the closing of operator wired into motor one outputs. Adjustable from 0 to 4 minutes (Same as pause time)	0
EL	MOTOR RUN TIME This enables where you choose from "simple" learning or "complete" learning of the motor run time. See page 10 & 11 for complete details. Simple Learning  ≈ 1 s. Complete Learning  > 3 s.	
In	EXIT PROGRAMMING Exit from programming and return to display of inputs status.	

* With Hydraulic operators the Force/Torque must be set to the maximum setting of 50.

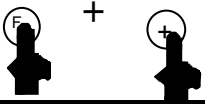
ADVANCED PROGRAMMING			Display	Function	De- fault
			59	INDICATOR-LIGHT: If 0 is selected, the output functions as a standard indicator-light (lighted at opening and pause, flashing at closing, and off when gate closed). Different figures correspond to timed activation of the output, which can be used (via a relay) to power a courtesy lamp. Time can be adjusted from 0 to 59s in 1s increments, and from 1.0 to 4.1 min. in 10s steps. 0 = Standard Indicator-Light From 1 to 4.1 = Timed Output	0
Display	Function	De- fault			
60	MAXIMUM TORQUE AT INITIAL THRUST: The motors operate at maximum torque (ignoring the torque setting) at start of movement. Useful for heavy leaves. 4 = Enable No = Disabled	no			
65	LAST STROKE AT CLOSING: The motors are activated at full speed for 1s to facilitate locking of the electric lock. 4 = Enable No = Disabled	no			
65	REVERSING STROKE: Before opening, while the gate is closed, the motors thrust to close for 2 s thus facilitating release of the electric lock. 4 = Enable No = Disabled	no	Ph	CLOSING PHOTOCELLS REVERSE AT RELEASE: Enable this function if you want the closing photocells to stop the gate movement and reverse it after the beam is cleared. Default setting is immediate reverse. 4 = Enable No = Disabled	0
00	LEAF 2 OPENING DELAY (2s): Enables delayed start (at opening) of leaf 2, avoiding interference between leaves. 4 = Enable No = Disabled	no	Ad	A.D.M.A.P. FUNCTION: If this function is enabled, the safety devices operate in compliance with French standard NFP 25/362. 4 = Enable No = Disabled	0
FS	FAIL SAFE: If this function is activated, it enables a function test of the photocells before any gate movement. If the test fails (photocells not serviceable), the gate does not start the movement. 4 = Enable No = Disabled	no	AS	ASSISTANCE REQUEST (COMBINED WITH NEXT FUNCTION): If activated, at the end of countdown (settable with the next function, i.e. "Cycle programming") it effects 8s of pre-flashing at every Open pulse (job request). Can be useful for setting scheduled maintenance jobs. 4 = Enable No = Disabled	0
PF	PRE FLASHING (5s): Activates the flashing lamp for 5s before start of movement. 4 = Enable No = Disabled	no	nc	CYCLE PROGRAMMING: For setting count down of system operation cycles. Settable (in thousands) from 0 to 99 thousand cycles. The displayed value is updated as cycles proceed. This function can be used to check use of the board or to exploit the "Assistance Request" function.	0
EL	ELECTRIC LOCK ON LEAF 2: For using the electric lock on leaf 2 instead of on leaf 1. 4 = Enable No = Disabled	no	In	EXIT PROGRAMMING: Exit from programming and return to display of inputs status.	

LEARNING OF OPERATING TIMES

WARNING: During the learning procedure, the safety devices are disabled! Therefore, any and all traffic must be avoided in the path of the gate leaf(s).

NOTE: Programming must start with the gate(s) in the closed position.

Opening/closing time is established by the learning procedure which varies slightly according to whether you are or are not using Gatecoders.

LEARNING OF NORMAL TIMES

Normal learning (i.e. without Gatecoders) can be done in two different ways:

SIMPLE LEARNING (WITHOUT SLOW DOWN)

Close the gates, enter "*BASIC PROGRAMMING*", select the TIME LEARNING function and press the + push-button for 1 second the display begins flashing and the leaves begin the opening movement.

Wait for the leaves to reach the opening positive stop and then supply an OPEN A command after the desired motor run time has been reached (by push-button or radio control) to stop the movement: the leaves stop and the display stops flashing. One more command given will close the gate.

The procedure has ended and the gate is ready to operate.

COMPLETE LEARNING (WITH SLOW DOWN)

NOTES:

- If you do not wish to slow the gate operator (s) down, wait for the gate to reach its positive stop and supply two (2) consecutive open commands (within 1 second).
- If only one gate operator (1) is used, you must go through the entire programming procedure, as if you were programming for two gate operators (2). When the operator has finished opening, supply 5 open commands until the gate operator begins to close, and then resume normal operations.

Close the gates, enter "*BASIC PROGRAMMING*", select the TIME LEARNING function and press the + push-button for more than 3 seconds: the display begins flashing and leaf 1 begins opening. The following functions can be commanded by the OPEN A (by push-button wired to terminals 9 and 14, or radio control):

- When gate operator (1) reaches the position that you want it to slow down, an open command must be given to start the slow down phase.
- When gate operator (1) reaches the positive stop and the desired motor run time has been reached, an open command must be given to shut the motor off. At this point gate operator (2) will automatically start to open.
- When gate operator (2) reaches the position that you want it to slow down, an open command must be given to start the slow down phase.
- When gate operator (2) reaches the positive stop and the desired motor run time has been reached, an open command must be given to shut the motor off. At this point gate operator (2) will automatically start to close.
- When gate operator (2) reaches the position that you want it to slow down, an open command must be given to start the slow down phase.
- When gate operator (2) reaches the positive stop and the desired motor run time has been reached, an open command must be given to shut the motor off. At this point gate operator (1) will automatically start to close.
- When gate operator (1) reaches the position that you want it to slow down, an open command must be given to start the slow down phase.
- When gate operator (1) reaches the positive stop and the desired motor run time has been reached, an open command must be given to shut the motor off.

The display stops flashing and the gate is ready for normal operation.

LEARNING TIMES WITH GATECODER

Learning with the Gatecoder can be done in two different ways:

SIMPLE LEARNING

Close the gates, enter "*Basic Programming*", select the TIME LEARNING function and press the + push-button for 1 second: the display begins flashing and the leaves begin the opening movement.

The movement stops automatically when the opening positive stop is reached and the display stops flashing.

The procedure has ended and the gate is ready to operate, using default slow down automatically set by the control panel.

COMPLETE LEARNING

NOTES:

- If only one gate operator (1) is used, you must go through the entire programming procedure, as if you were programming a gate operator (2). When the gate operator (1) has finished opening, supply 5 open commands until the gate operator begins to close, and then resume normal operations.

Close the gates, enter "BASIC PROGRAMMING", select the TIME LEARNING function and press the + push-button for more than 3 seconds: the display begins flashing and leaf 1 begins opening movement. The following functions can be commanded by the OPEN A command (by radio control or key push-button):

- When gate operator (1) reaches the position that you want it to slow down, an open command must be given to start the slow down phase. When the gate operator reaches its positive stop, the operator will automatically shut off.
- An open command must be given to start opening gate operator (2).
- When gate operator (2) reaches the position that you want it to slow down, an open command must be given to start the slow down phase. When the gate operator reaches its positive stop, the operator will automatically shut off.
- An open command must be given to start closing gate operator (2).

- When gate operator (2) reaches the position that you want it to slow down, an open command must be given to start the slow down phase. When the gate operator reaches its positive stop, the operator will automatically shut off.
- An open command must be given to start closing gate operator (1).
- When gate operator (1) reaches the position that you want it to slow down, an open command must be given to start the slow down phase. When the gate operator reaches its positive stop, the operator will automatically shut off.

The display stops flashing and the gate is ready for normal operation.

NOTES:

- The open command to slow down the gate should be given before the gate reaches the positive stop to prevent the gate from hitting the stop at full speed. The positive stop could be mistaken for an obstacle and then upon hitting it, the gate(s) would automatically reverse on contact.

AUTOMATED SYSTEM TEST

When you have finished programming, check if the system is operating correctly.

Most important of all, check that the force is adequately adjusted and that the safety devices are operating correctly.

If pressure adjustments on hydraulic operators are not set before programming. It may need to be reprogrammed for desired results.

A (Automatic) Logic (455 D)

Gate Status	Open A	Open B	Stop	Opening Reversing Device(s)	Closing Reversing Device(s)	Warning Light
Closed	Opens both leaves and closes them after pause time	Opens single leaf connected to Motor 1 and closes it after pause time	No effect	No effect	No effect	Off
Opening	No effect	No effect	Stops	Stops; gate closes when reversing device no longer triggered	No effect	On
Opened	Interrupts the pause time	Interrupts the pause time	Stops	No effect	Gate remains open until reversing devices no longer triggered	On
Closing	Opens both leaves	Opens leaf	Stops	No effect	Depends on DIP switch 4	Flashes
Stopped	Closes the leaves	Closes the leaf	No effect (opening is inhibited)	No effect	No effect (opening is inhibited)	On

S (Security) Logic (455 D)

Gate Status	Open A	Open B	Stop	Opening Reversing Device(s)	Closing Reversing Device(s)	Warning Light
Closed	Opens both leaves and closes them after pause time	Opens single leaf connected to Motor 1 and closes it after pause time	No effect	No effect	No effect	Off
Opening	Closes both leaves	Closes leaf	Stops	Stops; gate closes when reversing device no longer triggered	No effect	On
Opened	Closes both leaves	Closes leaf	Stops	No effect	Gate remains open until reversing devices no longer triggered	On
Closing	Opens both leave	Opens leaf	Stops	No effect	Depends on DIP switch 4	Flashes
Stopped	Closes the leaves	Closes the leaf	No effect (opening is inhibited)	No effect	No effect (opening is inhibited)	On

B (Manned, Pulsed) Logic (455 D)

Gate Status	Open A	Open B	Stop	Opening Reversing Device(s)	Closing Reversing Device(s)	Warning Light
Closed	Opens 1 or both leaves	No effect	No effect	No effect	No effect	Off
Opening	No effect	No effect	Stops	No effect	Stops	On
Opened	No effect	Closes 1 or both leaves	No effect	No effect	No effect	On
Closing	No effect	No effect	Stops	Stops	No effect	Flashes
Stopped	Opens 1 or both leaves	Closes 1 or both leaves	No effect	No effect	No effect	On

E (Semi-automatic) Logic (455 D)

Gate Status	Open A	Open B	Stop	Opening Reversing Device(s)	Closing Reversing Device(s)	Warning Light
Closed	Opens both leaves	Opens single leaf connected to Motor 1	No effect	No effect	No effect	Off
Opening	Stops	Stops	Stops	Stops; gate closes when reversing device no longer triggered	No effect	On
Opened	Closes both leaves	Closes leaf	Stops	No effect	No effect (opening is inhibited)	On
Closing	Closes both leaves	Closes leaf	Stops	No effect (opening is inhibited)	Depends on DIP switch 4	Flashes
Stopped	Closes the leaves	Closes the leaf	No effect (opening is inhibited)	No effect	No effect (opening is inhibited)	On

EP (Semi-automatic, Step by Step) Logic (455 D)

Gate Status	Open A	Open B	Stop	Opening Reversing Device(s)	Closing Reversing Device(s)	Warning Light
Closed	Opens both leaves	Opens single leaf connected to Motor 1	No effect (opening is inhibited)	No effect (opening is inhibited)	No effect (opening is inhibited)	Off
Opening	Stops	Stops	Stops	Stops; gate closes when reversing device no longer triggered	No effect	On
Opened	Closes both leaves	Closes leaf	Stops	No effect	No effect (opening is inhibited)	On
Closing	Stops	Stops	Stops	No effect (opening is inhibited)	Depends on DIP switch 4	Flashes
Stopped	Gate leaves reverse direction	Gate leaf reverses direction	No effect (opening is inhibited)	No effect (opening is inhibited)	No effect (opening is inhibited)	On

C (Manned and Constant) Logic (455 D)

Gate Status	Open A	Open B	Stop	Opening Reversing Device(s)	Closing Reversing Devices(s)	Warning Light
Closed	Opens 1 or both leaves	No effect	No effect	No effect	No effect	Off
Opening	No effect	No effect	Stops	No effect	Stops	On
Opened	No effect	Closes 1 or both leaves	No effect	No effect	No effect	On
Closing	No effect	No effect	Stops	Stops	No effect	Flashes
Stopped	Opens 1 or both leaves	Closes 1 or both leaves	No effect	No effect	No effect	On

MAINTENANCE

THE 402 OPERATOR

The FAAC recommended maintenance schedule varies according to the frequency of use of the operators, whether lightly used operators (once or twice an hour) or heavily used operators (many cycles per hour), operators used in a humid, salt air climate should follow the heavy duty use schedule.

CHECK THE OIL.

To check the oil level correctly, remove the operator from the gate leaf. With the piston rod completely retracted and pointing to the ground, remove the rear flange and look at the oil level in the casing of the operator. The oil level should be about 3/4 in. (20 mm) from the top edge of the operator casing. If the operator is too full, it will bleed oil out the vent hole.

Light duty use: every 12 mo

Heavy duty use: every 6 mo

CHANGE THE OIL.

Light duty use: every 48 mo or 4 yrs

Heavy duty use: every 24 mo or 2 yrs

CHECK THE PRESSURE SETTINGS.

Light duty use: every 12 mo

Heavy duty use: every 6 mo

THE 455 D CONTROL PANEL

Keep the Control Panel free from spider webs, insects, etc. Otherwise the Control Panel requires no maintenance.

SAFETY IN GATE DESIGN

- A gate is a potential traffic hazard, so it is important that you locate the gate far enough away from the road to eliminate the potential of traffic getting backed up. This distance is affected by the size of the gate, how often it is used, and how fast the gate operates.
- The operator you choose to install on your gate must be designed for the type and size of your gate and for the frequency with which you use the operator.
- Your gate must be properly installed and must work freely in both directions *before* the automatic operator is installed.
- An automatic operator should be installed on the inside of the property/fence line. Do not install the operator on the public side of the property/fence line.
- Outward swinging gates with automatic operators should not open into a public area.
- Pedestrians should not use a vehicular gate system. Prevent such inappropriate use by installing separate gates for pedestrians.
- The operating controls for an automatic gate must be secured to prevent the unauthorized use of those controls.
- The controls for an automatic gate should be located far enough from the gate so that a user cannot accidentally touch the gate when operating the controls.
- Exposed, reachable pinch points on a gate are potentially hazardous and must be eliminated or guarded.
- It is extremely unsafe to compensate for a damaged gate by over tightening a clutch or increasing hydraulic pressure.
- An automatic gate operator should not be installed on a gate if people can reach or extend their arms or legs through the gate. Such gates should be guarded or screened to

TROUBLESHOOTING

WARNING! Before you do any work on the control panel, be sure to turn off the main power.

PROBLEM: THE GATE DOES NOT OPEN COMPLETELY.

SOLUTION:

Check the gate for mechanical obstacles that might prevent the gate from opening.

If the motor stops running before the gate is completely open (or closed), you need to adjust the opening/closing time for the operator or check the bypass valve adjustment. On the one hand, you can increase the opening/closing time of the operator so that it runs long enough to close the gate. You can, on the other hand, increase the pressure. If the pressure is too weak the leaf movement may slip, preventing full closure before the motor stops running.

Check your dimensions for mounting the rear bracket. Incorrect dimensions can make a full 90-deg swing impossible.

PROBLEM: THE GATE OPENS BUT DOES NOT CLOSE.

SOLUTION:

Verify that you have correctly wired the operator to the control panel.

Verify that the reversing devices are working properly.

If you have installed no reversing devices, make sure that you have installed a jumper wire across the reversing device terminals on the control panel.

If the motors are running, insure that the bypass valve pressure adjustment is correct.

PROBLEM: THE RADIO CONTROLLED OPENER DOES NOT OPEN THE GATE.

SOLUTION:

Check the light on the front of the remote transmitter. It should illuminate when you signal the gate. If it doesn't illuminate and if the batteries are okay, repair or replace the transmitter.

Verify that the codes on the receiver and transmitter are the same.

Verify that the wiring for the radio controlled devices is correct.

Check the fuses on the control panel.

Check the wiring for the antenna and correct it if necessary.

Determine if the fault is in the receiver by temporarily connecting a push button device across the control panel activating terminals. If such a push button device opens the gate, repair or replace the receiver

LIMITED WARRANTY

To the original purchaser only: FAAC International, Inc., warrants, for twenty-four (24) months from the date of invoice, the gate operator systems and other related systems and equipment manufactured by FAAC S.p.A. and distributed by FAAC International, Inc., to be free from defects in material and workmanship under normal use and service for which it was intended *provided* it has been properly installed and operated. FAAC International, Inc.'s obligations under this warranty shall be limited to the repair or exchange of any part of parts manufactured by FAAC S.p.A. and distributed by FAAC International, Inc. Defective products must be returned to FAAC International, Inc., freight prepaid by purchaser, within the warranty period. Items returned will be repaired or replaced, at FAAC International, Inc.'s option, upon an examination of the product by FAAC International, Inc., which discloses, to the satisfaction of FAAC International, Inc., that the item is defective. FAAC International, Inc. will return the warranted item freight prepaid. The products manufactured by FAAC S.p.A. and distributed by FAAC International, Inc., are not warranted to meet the specific requirements, if any, of safety codes of any particular state, municipality, or other jurisdiction, and neither FAAC S.p.A. or FAAC International, Inc., assume any risk or liability whatsoever resulting from the use thereof, whether used singly or in combination with other machines or apparatus.

Any products and parts not manufactured by FAAC S.p.A. and distributed by FAAC International, Inc., will carry only the warranty, if any, of the manufacturer. This warranty shall not apply to any products or parts thereof which have been repaired or altered, without FAAC International, Inc.'s written consent, outside of FAAC International, Inc.'s workshop, or altered in any way so as, in the judgment of FAAC International, Inc., to affect adversely the stability or reliability of the product(s) or has been subject to misuse, negligence, or accident, or has not been operated in accordance with FAAC

International, Inc.'s or FAAC S.p.A.'s instructions or has been operated under conditions more severe than, or otherwise exceeding, those set forth in the specifications for such product(s). Neither FAAC S.p.A. or FAAC International, Inc., shall be liable for any loss or damage whatsoever resulting, directly or indirectly, from the use or loss of use of the product(s). Without limiting the foregoing, this exclusion from liability embraces a purchaser's expenses for downtime or for making up downtime, damages for which the purchaser may be liable to other persons, damages to property, and injury to or death of any persons. Neither FAAC S.p.A. or FAAC International, Inc., assumes nor authorizes any person to assume for them any other liability in connection with the sale or use of the products of FAAC S.p.A. or FAAC International, Inc. The warranty hereinabove set forth shall not be deemed to cover maintenance parts, including, but not limited to, hydraulic oil, filters, or the like. No agreement to replace or repair shall constitute an admission by FAAC S.p.A. or FAAC International, Inc., of any legal responsibility to effect such replacement, to make such repair, or otherwise. This limited warranty extends only to wholesale customers who buy directly through FAAC International, Inc.'s normal distribution channels. FAAC International, Inc., does not warrant its products to end consumers. Consumers must inquire from their selling dealer as to the nature and extent of that dealer's warranty, if any.

This warranty is expressly in lieu of all other warranties expressed or implied including the warranties of merchantability and fitness for use. This warranty shall not apply to products or any part thereof which have been subject to accident, negligence, alteration, abuse, or misuse or if damage was due to improper installation or use of improper power source, or if damage was caused by fire, flood, lightning, electrical power surge, explosion, wind storm, hail, aircraft or vehicles, vandalism, riot or civil commotion, or acts of God.

**FAAC International, Inc.
303 Lexington Avenue
Cheyenne, WY 82007
www.faacusa.com**